



SKIFF RACING ASSOCIATION

HANDBOOK

This Handbook is published upon the authority of the Committee of the Skiff Racing Association. It cancels and supersedes all previous publications.

This handbook may be downloaded and printed from the Skiff Racing Association website.

Copies of this Handbook may be obtained from the Honorary Secretary of the Skiff Racing Association for a nominal charge. The name and address of the Honorary Secretary will be found in the current British Rowing Almanac, under the heading 'Skiff Racing'.

RECORD OF REVISIONS

Revision	Issue Date	Page No.
L	01.08.17	Restructure and changes: 10 - 5 (remove text); 29 - D6, D7, D8 (decrease points); 52 - 1 (enhance criteria); 53 all (new section); 63,64,65 all (new section)
M	20.04.18	23-27 A3, B8, C2 (Include processional options); 28/29 D9 (rule for entrant events); 32 F1 (note for processional rules); 34 F23 (rule for false appeal); 41-45 (restructure section for processional events);52 (Remove rule on Juniors competing in status events); 53 (Clarify Ormiston rules when status events are included in Tiny/Nancy Knight events)
N	04.03.19	2 p3 (contact details); 6 p14 (associates); 8 p1 (redefine); 9 p3 (process), p3-10 (<i>reformat</i>); 19 add Foul and Interference from Sect F; 20 A2 (Organising Committee), A7 (events); 21 B heading, B7 (start times); 23 C heading, C1-8 (<i>reformat</i>), C9 (raft marshal), C10 (programme), C11 (Xref to H); 24 C10 notes (missing handicaps); 25 D10 (exclude processional races); 26 E2b (para refs); 28-31 F all paras (<i>reformat</i>) F28 (precision); 33 F24 note (finish procedure); 34 G2-G7 (<i>reformat</i>); 36 H1 (<i>reformat</i>); 37 H6d (notification of penalties), H7 (remove exclusion); 42 p5 (birth detail year only)

CONTENTS

	<u>Page No.</u>
Abbreviations and Definitions	1
Constitution	2
Associate Membership	8
Appointment of Umpires	9
Construction and Dimensions of Racing Skiffs and Sculls	10
Rules of Racing	19
Section A - General	20
Section B – SRA Competition Conditions and Entries	21
Section C – SRA Competition Regulations	23
Section D - Categories of Events	25
Section E – Status Points for Competitors	26
Section F - Race Regulations	28
Section G - Disputes and Disciplinary Procedures	34
Section H - Processional Races	36
Section J - Safety Regulations	40
Veteran Racing	42
The Veteran Pennant	44
The Junior Pennant	45
Ormiston Memorial Trophy	47
Most Improved Sculler of the Year Award	48
Junior Sculler of the Year Award	49
Inter-club Team Races	50

ABBREVIATIONS AND DEFINITIONS

The abbreviation SRA is used throughout for 'Skiff Racing Association'.

The abbreviation BR is used throughout for 'British Rowing'.

The masculine shall be deemed to include the feminine except where the contrary appears.

CONSTITUTION

1. Objects

The Association (founded in 1901) shall be called 'The Skiff Racing Association'; it is hereinafter referred to as the SRA and its objects shall be:

- (a) To maintain the standard of sculling in skiff and kindred races.
- (b) To promote the interests of skiff racing and kindred sports.

2. Composition

The SRA shall consist of clubs and regattas affiliated in accordance with Article 3.

3. Affiliation

Any club or regatta willing to bind itself to observe the constitution and rules of the SRA may become affiliated upon making application to the Hon. Secretary and being duly elected by a majority of two-thirds of a meeting of the Committee. A regatta organized by an affiliated club, as part of its programme, may not itself become affiliated.

Each club or regatta on becoming affiliated to the SRA, and thereafter from time to time as necessary, shall send to the Hon. Secretary the name and address, telephone number and e-mail address of the person to whom communications shall be sent. Notices sent by the Hon. Secretary to the name and address last given shall be deemed to have been properly sent to the affiliated club or regatta whether received or not.

Each affiliated club shall, when required, send to the Hon. Secretary a list of its members and a copy of its last Balance Sheet.

Each affiliated regatta shall, when required, send to the Hon. Secretary a list showing the names of the members of the regatta committee and a copy of its last Balance Sheet.

The racing colours of each affiliated club at the time of affiliation, and any subsequent change in them, shall be notified to the Hon. Secretary.

4. Subscription

Each affiliated club and regatta shall pay to the SRA an annual subscription the amount of which, in respect of the right to each vote as defined in Article 10, shall be decided by the Committee each year. The said amount shall be notified to each club or regatta after each Annual General Meeting.

Subscriptions shall fall due upon demand and shall be paid not later than the 1st June each year. Should the subscription of an affiliated club become overdue, the nominated Committee member of such a club shall be ineligible to vote at Committee meetings until the overdue subscription has been paid.

5. Government

The government and management of the SRA shall be vested in the Committee, who shall meet at least once in every six months or as often as may be required.

The Hon. Secretary may call a Committee meeting at any time found necessary, and shall do so within 14 days if requested in writing by not less than eight members of the Committee.

The Chairman shall preside at Committee meetings, but in his absence a chairman shall be elected for the occasion from among the Committee members present.

Eight members of the Committee shall form a quorum and the Chairman shall have a casting vote.

6. Constitution of the Committee

The Committee shall consist of the President, the nominated and elected members, the Hon. Officers, and the Chairman.

- (a) The nominated members shall be one member nominated each year by each of the affiliated clubs.

A vacancy occurring among the nominated members shall be filled by the nominating club.

The name and address of its nominated member shall be notified to the Hon. Secretary in writing by each affiliated club not later than the 31st March each year. Failing such notification the previously nominated member shall be deemed to continue in office.

- (b) The elected members, each of whom must be a member of an affiliated club or a member of the committee of an affiliated regatta, shall not exceed ten in number and shall be elected according to Article 12.

Elected members shall retain office for two years and shall be eligible for re-election upon retirement.

A vacancy by reason of retirement or death occurring among the elected members may be filled by resolution of the Committee, and a person so appointed shall hold office until the next Annual General Meeting.

- (c) The Hon. Officers shall be the Hon. Secretary and such others not exceeding two in number as may have been appointed by the Committee. One of these two appointments shall be that of the Honorary Treasurer, but the Hon. Secretary may undertake the duties of either or both such Hon. Officers.

- (d) The Hon. Officers and the Chairman shall be elected annually by the Committee, either from among the Committee or from outside, at the first Committee meeting following the Annual General Meeting, provided always that a person so elected from outside the Committee shall be a member of an affiliated club or a member of the committee of an affiliated regatta.

A vacancy by reason of retirement or death occurring among the Hon. Officers and Chairman may be filled by resolution of the Committee, and a person so appointed shall hold office until the next annual election.

7. Honorary Officers

The Hon. Secretary shall keep a proper record of the proceedings of the Committee and General Meetings. The Hon. Treasurer shall be responsible for the books, accounts and funds of the SRA and shall submit an audited account each year for presentation to the next Annual General Meeting.

In the event that the Hon. Secretary resigns or is otherwise unable to fulfil his duties, the responsibility for calling a Committee meeting to elect a replacement, or for calling a General Meeting, shall fall on the Chairman, or failing him, in order, another Hon. Officer, the President, or members of the Committee in alphabetical order of surname.

8. Powers and Duties of the Committee

The Committee's powers and duties shall be:

- (a) To consider, and thereafter approve or reject, applications for affiliation of clubs and regattas according to Article 3.
- (b) To suspend or remove affiliated clubs and regattas according to Article 15.
- (c) To set the annual subscription to the affiliated clubs and regattas according to Article 4.
- (d) To elect annually the Hon. Officers and Chairman of the SRA Committee according to Article 6(d).
- (e) To fill vacancies occurring among the members of the Committee, or in the office of Hon. Examiner, according to Articles 6(b), 6(d) and 13(d).
- (f) To call Special General Meetings according to Article 9.
- (g) To elect persons to, or remove persons from, Associate Membership of the SRA according to Article 14 and the section entitled 'Associate Membership', and to appoint annually an Associate Members' Hon. Secretary.
- (h) To amend the Constitution of the SRA according to Article 16.
- (i) To amend the SRA Rules of Racing and such other rules and regulations as may, within the sections of this Handbook, be within the province of the SRA.

- (j) To fix annually the regatta calendar according to Rules A5 and A6 of the SRA Rules of Racing.
- (k) To appoint Qualified and Probationary umpires according to the section entitled 'Appointment of Umpires'.
- (l) To organize the SRA Inter-Club Team Races, and organize or control marathons and other processional races, according to the relevant sections of this Handbook.
- (m) To appoint a Status Records Recorder to keep a register of each competitor's wins and classification in SRA-affiliated regattas and regattas organized by SRA-affiliated clubs according to the SRA Rules of Racing, Sections D and E.
- (n) To appoint a Veteran Records Recorder according to the section entitled 'Veteran Racing'.
- (o) To appoint an Ormiston Points Recorder according to the section entitled Ormiston Memorial Trophy'.
- (p) To appoint a Junior Pennant Points Recorder according to the section entitled 'The Junior Pennant'
- (q) To specify the construction and dimensions of racing skiffs and sculls according to Rule C1 of the SRA Rules of Racing.
- (r) To impose penalties in accordance with Rule G10 of the SRA Rules of Racing.
- (s) Generally to determine and settle all questions and disputes concerning skiff racing and kindred sports that may be referred to them for decision.
- (t) To decide annually the winner of the 'Most Improved Sculler of the Year Award', and to purchase and present the award according to the section entitled 'Most Improved Sculler of the Year Award'.
- (u) To decide annually the winner of the 'Junior Sculler of the Year Award', and to purchase and present the award according to the section entitled 'Junior Sculler of the Year Award'.
- (v) Furthermore the Committee shall take such other steps that they may consider necessary or expedient for carrying into effect the objects of the SRA, including the possible acquisition of equipment that may reasonably be shared between affiliated clubs and regattas on a loan or hire basis.

Provided always that the Committee shall have no power to make or alter any rule in Section F (Race Regulations) in the SRA Rules of Racing so as to make such rule conflict with the spirit of an equivalent BR rule.

9. General Meetings

A General Meeting of the members of affiliated clubs, the members of the committees of affiliated regattas, the Committee and the Associate Members, shall be summoned by the Hon. Secretary once each year for the following purposes, and for such other purposes as may have been decided by the Committee:

- (a) To receive, and approve or otherwise, the Committee's Report.
- (b) To receive, and approve or otherwise, the audited accounts.
- (c) To elect the President of the SRA.
- (d) To elect members of the Committee in place of those retiring according to Article 6(b).
- (e) To elect a Hon. Examiner.

Each such meeting shall be called the Annual General Meeting and shall be held during the month of April, unless special circumstances prevail.

Special General Meetings may be called at any time by resolution of the Committee.

Except for the special procedures for electing the President and the Committee according to Articles 11 and 12 respectively, each person present at a General Meeting may speak, propose or second any motion, and exercise the right to one vote.

The President of the SRA shall take the Chair at General Meetings or, in his absence, the Chairman shall be appointed by the meeting. Except during the election of the President, the Chairman shall have a casting vote.

The Hon. Secretary shall give not less than ten days notice in writing to each affiliated club and regatta, to the Committee and to the Associate Members, of the time, place and agenda of each General Meeting, and shall require each affiliated club and regatta to notify him, in writing, not less than three days before the meeting, of the name of their representative who shall be entitled to exercise the votes to which the club or regatta is entitled.

10. Voting Powers of Affiliated Clubs and Regattas

For the purposes of electing the President of the SRA, and the Committee, at the Annual General Meeting, or for such other purposes at a Special General Meeting that the Committee may deem appropriate, the affiliated clubs and regattas shall have the power to vote as follows, provided always that the subscriptions of such clubs and regattas are not in arrears at the time of voting and that the names of their representatives have been notified to the Hon. Secretary according to Article 9:

- (a) Each club devoted solely to skiff racing or to skiff racing and kindred sports, one vote, and for every 50 members in excess of 50 another vote, with a maximum of four votes.
- (b) Each skiff regatta holding an open event or events in each year, two votes.
- (c) Each club not devoted solely to skiff racing but occasionally entering skiff events, one vote.

The term 'member' in this Article shall only include a person aged 18 or over who pays an annual subscription to the club, or has become a life member or honorary member thereof according to the Rules of the club. Each adult member of a family membership shall count as one member.

For the purposes of this Article the membership of an affiliated club shall be that obtaining at the time the demand for the affiliation fee is made.

The votes to which an affiliated club or regatta shall be entitled at a General Meeting shall derive from the payment of the last preceding subscription according to Article 4. The rights to such votes shall remain with the affiliated club or regatta until such time as the Hon. Secretary has issued the demand for the affiliation fee in respect of the next ensuing year.

11. President of the SRA

The President of the SRA shall be elected at the Annual General Meeting.

- (a) The Hon. Secretary shall invite nominations from the representatives of the affiliated clubs and regattas, and the Associate Members, present and no others. Each nomination shall be proposed and seconded.
- (b) Each person nominated shall have indicated his willingness to serve if elected, and shall be a member of an affiliated club or a committee member of an affiliated regatta.
- (c) A ballot shall take place if there is more than one candidate. Those eligible to vote are Associate Members, who are entitled to one vote, and the representatives of affiliated clubs and regattas, with voting powers as specified in Article 10.
- (d) The Hon. Secretary shall furnish voting papers; each representing one vote, to those entitled to vote. The voting papers shall be collected by scrutineers, elected from among those present, who shall report to the Chairman of the meeting the result of the ballot.
- (e) If the ballot should result in a tie, the successful candidate shall be chosen by the toss of a coin or by such other means as the meeting may decide.
- (f) A President who has been elected five years successively may not stand for election in the sixth year.

12. Election of Committee

The election of members of the Committee shall be carried out as follows at each Annual General Meeting:

- (a) The Hon. Secretary shall invite nominations from the representatives of the affiliated clubs and regattas present and no others. Each nomination shall be proposed and seconded.
- (b) Each person nominated shall have indicated his willingness to serve on the Committee if elected, and shall be a member of an affiliated club or a member of the committee of an affiliated regatta.
- (c) If five or fewer nominations, each duly proposed and seconded, are received, the persons so nominated shall be deemed

elected members according to Article 6(b).

- (d) If more than five nominations are received, a ballot shall take place, the Hon. Secretary furnishing voting papers, each representing one vote, to the representative of each affiliated club and regatta present.
- (e) Each vote shall entitle the representative to cast a vote for any five, neither more nor less, of the candidates; otherwise the vote shall be invalid.
- (f) The voting papers shall be collected by two scrutineers, elected from among those present, who shall report to the Chairman of the meeting the results of the ballot.
- (g) The candidates elected shall be the five who secure the highest number of votes.

If the vote fails to identify five clear successful candidates because of two or more candidates tying for the last place or places, then those tying candidates shall be subject to a further ballot.

If at any Annual General Meeting there is a person who has filled by resolution of the Committee a vacancy caused by the retirement or death of an elected member whose two year term of office had a further year to run, the election of a person to fill the vacancy for the remaining year shall be the subject of nominations and a ballot which shall be conducted in the manner set out above.

13. Honorary Examiner

The Hon. Examiner of the SRA shall be elected at the Annual General Meeting.

- (a) The Hon. Secretary shall invite nominations from anyone present at the meeting. Each nomination shall be proposed and seconded.
- (b) Each person nominated shall have indicated his willingness to serve if elected, and need not be a member of an affiliated club or a committee member of an affiliated regatta.
- (c) A vote shall take place if there is more than one candidate, each person present at the meeting being entitled to one vote.
- (d) A vacancy by reason of retirement or death occurring in the office of Hon. Examiner may be filled by resolution of the Committee, and a person so appointed shall hold office until the next Annual General Meeting.

14. Associate Members

Present or past scullers and others who have rendered service to skiff racing or have an interest in the SRA, shall be eligible for election to Associate Membership of the SRA for such term and on such conditions as the Committee may from time to time decide.

15. Suspension and Removal

An affiliated club or regatta whose subscription has been in arrears for three consecutive years shall be liable to be removed from the SRA by resolution of the Committee, who shall also have the power, on any other due cause being shown, to suspend or remove any affiliated club or regatta from the SRA.

No motion for the suspension or removal of an affiliated club or regatta shall be considered except at a Committee meeting specially called at not less than 7 days notice for that purpose. Such a motion shall not be deemed carried except by a majority of two thirds of the Committee present.

A resolution for the removal of an affiliated club or regatta from the SRA must be confirmed at a subsequent meeting of the Committee to be held within one month of the first meeting and specially summoned at not less than 7 days notice for that purpose. Such confirmation shall not be deemed carried except by a majority of two thirds of the Committee present.

16. Alteration of the Constitution

No addition to, or alteration of, the Articles of the Constitution shall be made except by the vote of at least two thirds of the members present at a meeting of the Committee specially summoned at not less than 7 days notice for the purpose. The notice summoning the meeting shall set out in full the additions or alterations proposed.

17. Dissolution

If, upon the winding up or dissolution of the SRA, there remains, after the satisfaction of all its debts and liabilities, any property whatsoever, the same shall not be paid to or distributed among the Associate Members or any other individuals, but shall be given to some charitable or sporting organization or organizations, such organization or organizations to be determined at a Special General Meeting called at or before the time of dissolution.

ASSOCIATE MEMBERSHIP

BACKGROUND

The Associate Membership of the SRA was inaugurated by the SRA Committee in 1962 as a means of augmenting the annual income of the SRA.

RULES

1. Associate Members of the SRA shall be present or past scullers and others who have rendered service to skiff racing or have an interest in the SRA. They shall have been elected by ballot with simple majority by the Committee of the SRA.
2. Nominations for election to Associate Membership shall be made only by members of the Committee of the SRA, and shall be circulated to all members of the Committee.
3. Upon being elected, and thereafter annually on 1st January, each Associate Member shall contribute to the SRA funds such sum as the Committee shall from time to time decide.

Life Associate Members may be elected, with or without subscription, at the discretion of the Committee.

4. The Committee shall have the power, on due cause being shown, to remove any Associate Member from the Membership. A motion in Committee to remove an Associate Member shall not be deemed carried except by a majority of two thirds of the Committee present.
5. Under Articles 9 and 11 of the Constitution, each Associate Member shall be entitled to attend the Annual General Meeting and to cast a vote in the election of the President.

Associate Members shall be entitled to wear SRA Associate Members' insignia.

6. The register and records of the Associate Members shall be kept by the Associate Members' Hon. Secretary, who shall be appointed annually by the Committee.

APPOINTMENT OF UMPIRES

1 The SRA Committee is the body responsible for decisions on all matters concerning umpiring, but each year the Committee shall, from the panel of qualified umpires, select three umpires or more, as the Committee may decide, to form a Qualified Umpires Sub-Committee to advise it on such matters. The Sub-Committee shall choose one of its members to act as Chairman.

2 The Sub-Committee shall have responsibility for ensuring that a high standard of umpiring is maintained. It shall make recommendations to the SRA Committee concerning the following

- a) Appointment or disqualification of qualified and probationary umpires,
- b) the resolution of complaints and disputes about umpiring
- c) the recipient of the Most Improved Sculler of the Year Award.

The Sub-Committee shall present an annual report to the SRA Committee.

3 Persons who wish to qualify as umpires should in the first instance be recommended by the captains of their clubs through a submission to the Hon. Secretary of the SRA which will be forwarded to the Chairman of the Sub-Committee. They shall then be required to take a written examination, set by the Sub-Committee, on the SRA Rules of Racing and the Rules of Junior and Veteran Racing. The examination shall take place at such location and on such date as the Sub-Committee shall decide. The pass-level mark for this examination shall be set at approximately 80%. Those who pass the examination shall, with the approval of the SRA Committee, be graded Probationary Umpire. Those who fail the examination may re-take it on the next possible occasion.

4 Probationary umpires shall be required to attend a number of regattas and, with the agreement of the regatta Organising Committee concerned, undertake official duties under the supervision of a qualified umpire. Such duties may include starting and aligning, judging, bank umpiring, and umpiring from a launch. Organising Committees may themselves appoint probationary umpires as judges (but not as chief judges) and as other officials under Race Regulations F3 and F4.

A probationary umpire may umpire, without supervision, long-distance events, and events closed to the members of his own club.

5 When the Sub-Committee, in consultation with qualified umpires who have acted as supervisors, is satisfied that a probationary umpire has shown the required degree of competence on a sufficient number of occasions, it may recommend to the SRA Committee that the probationary umpire be upgraded to Qualified Umpire.

6 A qualified or probationary umpire may at any time resign his appointment by writing to the Hon. Secretary of the SRA or to the Chairman of the Sub-Committee.

The Sub-Committee may recommend to the SRA Committee that the appointment of a qualified or probationary umpire should be terminated if, in the opinion of the Sub-Committee, that umpire is no longer capable of carrying out his duties satisfactorily.

7. Qualified umpires shall be expected to make themselves available for official duties at regattas whenever possible. All umpires, both qualified and probationary, are expected to be suitably dressed for the occasion; this means wearing a jacket (preferably a blazer) and tie.

8. If, in accordance with Section A3 of the SRA Rules of Racing, the holder of a BR Umpires Licence is used as an umpire at a skiff regatta, the Sub-Committee shall ensure that the umpire is made aware of the salient differences between the BR and SRA Rules of Racing.

9. Each year, or at such other interval as the Sub-Committee may decide, a meeting of all qualified and probationary umpires shall be held at which any points relating to umpiring or other matters of general concern may be discussed. Umpires shall be expected to attend all these meetings if possible, but at least one in three.

10. The Hon. Secretary of the SRA shall publish a list containing the names, addresses and telephone numbers of all qualified and probationary umpires, and shall distribute it to all affiliated clubs and regattas and to all qualified and probationary umpires. The Hon. Secretary shall ensure that the published list is at all times up to date.

CONSTRUCTION AND DIMENSIONS OF RACING SKIFFS AND SCULLS

1. Introduction

In June 1965 the SRA appointed a Sub-Committee to record the leading dimensions of the affiliated clubs' racing skiffs and sculls in current use and to make recommendations for standardizing their dimensions and form of construction. The Sub-Committee made a final report in March 1968 as a result of which the SRA approved a set of dimensions to which all new-construction skiffs and sculls should adhere; these dimensions are here referred to as 'mandatory dimensions'. In 1996 some further dimensions were added, but only as recommendations, and are hence here referred to as 'recommended dimensions'.

2. Construction of Skiffs (Figures 1 and 2)

Single and double skiffs approved by the SRA for use in regattas shall be of wooden, clinker-built construction with a minimum of six strakes each side excluding the gunwale. They shall have a keel protected by a metal keel-band, and it is usual to fit a rubbing strake, with or without a protecting metal band, to the junction of the second and third strakes away from the keel. They shall each carry fore, centre, and aft burden boards. All skiffs shall be propelled by sculls working between fixed, strung tholes, each thole to present a half-circle profile in section to the scull and a straight vertical profile (Figure 3); and there shall be a brass sill between tholes to protect the gunwale. Each sculler is to be seated on a fixed thwart and is to be provided with a locking stretcher with toe-straps, the stretcher to be adjustable in a fore-and-aft direction (Figure 4). Double skiffs shall carry a coxswain, seated on a fixed thwart, who shall steer the skiff by means of a rudder pivoted at the sternpost.

3. Dimensions of Skiffs

Table 1A gives the mandatory and recommended dimensions of single and double skiffs in imperial measure. In Table 1B the same information is given in metric units. The important recommended dimensions concern the stretcher and its adjustment.

4. Construction of Sculls (Figures 5 and 6)

There is no restriction on the material used for sculls, though they are normally of wood with either a tubular or girder construction. Each scull must have a protective leather or plastic sleeve over that part of the loom in contact with the tholes, and on which shall be attached an angled button, normally built up from layers of leather. This part of the scull must include a 'flat' parallel with the blade and on the same side as the convex face of it, i.e. the 'flat' must be in contact with the working thole during the stroke and in contact with the sill during feathering. It is normal to fit a rubber grip over the handle of the loom.

5. Dimensions of Sculls

The mandatory and recommended dimensions of bow and stroke sculls are given in Table 2A in imperial measure, with the same information in Table 2B in metric units. The mandatory dimensions concern the cross-section at the button (Figure 6), which must work within the thole dimensions. There is some scope for variation in the recommended dimensions (Figure 5), particularly in the outboard dimension and the dimensions and shape of the blade, but there is little scope for variation in the inboard dimension if the overlap is to be kept within reasonable limits; the overlap tolerance includes the tolerances of the inboard length and the distance between the sills. The recommended dimensions are typical of the sculls in current use. The tables also give the outboard/inboard ratio or gearing of the sculls based on the recommended dimensions; it can be seen that the bow sculls have a slightly harder gearing than the stroke sculls.

CONSTRUCTION OF SKIFFS

TABLE 1A - SKIFF DIMENSIONS (FIGURES 1 TO 4) - IMPERIAL UNITS

CODE	DIMENSIONAL DESCRIPTION	DIMENSION	TOLERANCE
	<u>MANDATORY DIMENSIONS</u>		
A	Overall length - Singles - Doubles	23' 10" 25' 10"	± 1½" ± 1½"
B	Stem to bow working thole - Singles - Doubles	13' 6" 10' 6½"	± 1" ± 1"
C	Bow working thole to stroke working thole - (Doubles)	4' 0"	± ½"
D	Working thole to aft of thwart (all positions)	12½"	± ⅜"
E	Stroke working thole to forward edge of coxswain's thwart - (Doubles)	3' 11"	± ½"
F	Width between sills - Singles and bow position in Doubles	3' 9"	± ½"
G	Width between sills - Stroke position in Doubles	4' 0"	± ½"
H	Thwart-top height from burden boards (all positions)	8"	± ½"
J	Sill height from top of thwart (all positions)	7"	± ½"
K	Sill height from burden boards (= H + J)	15"	± 1"
L	Distance between tholes	4½"	± ⅜"
M	Clear height from sill to string	2⅝"	± ¼"
	<u>RECOMMENDED DIMENSIONS</u>		
N	Width of sculling thwart (all positions)	7½"	± ¼"
P	Width of coxswain's thwart	13"	± ½"
Q	Height of thole from sill	4½"	- 0 + ½"
R	Nearest distance of stretcher heel from thwart (all positions)	22"	maximum
S	Farthest distance of stretcher heel from thwart (all positions)	33"	minimum
T	Adjustment range of stretcher	12¾"	minimum
-	Adjustment pitch of stretcher	¾"	maximum
U	Angle of stretcher from vertical	35°	± 5°

CONSTRUCTION OF SKIFFS

TABLE 1B - SKIFF DIMENSIONS (FIGURES 1 TO 4) - METRIC UNITS (cm)

CODE	DIMENSIONAL DESCRIPTION	DIMENSION	TOLERANCE
	<u>MANDATORY DIMENSIONS</u>		
A	Overall length - Singles - Doubles	726.44 787.40	± 3.81 ± 3.81
B	Stem to bow working thole - Singles - Doubles	411.48 321.31	± 2.54 ± 2.54
C	Bow working thole to stroke working thole - (Doubles)	121.92	± 1.27
D	Working thole to aft of thwart (all positions)	31.75	± 0.95
E	Stroke working thole to forward edge of coxswain's thwart- (Doubles)	119.38	± 1.27
F	Width between sills - Singles and bow position in Doubles	114.30	± 1.27
G	Width between sills - Stroke position in Doubles	121.92	± 1.27
H	Thwart-top height from burden boards (all positions)	20.32	± 1.27
J	Sill height from top of thwart (all positions)	17.78	± 1.27
K	Sill height from burden boards (= H + J)	38.10	± 2.54
L	Distance between tholes	11.43	± 0.48
M	Clear height from sill to string	6.67	± 0.64
	<u>RECOMMENDED DIMENSIONS</u>		
N	Width of sculling thwart (all positions)	19.05	± 0.64
P	Width of coxswain's thwart	33.02	± 1.27
Q	Height of thole from sill	11.43	- 0 + 1.27
R	Nearest distance of stretcher heel from thwart (all positions)	55.88	maximum
S	Farthest distance of stretcher heel from thwart (all positions)	83.82	minimum
T	Adjustment range of stretcher	32.39	minimum
-	Adjustment pitch of stretcher	1.91	maximum
U	Angle of stretcher from vertical	35°	± 5°

CONSTRUCTION OF SKIFFS

TABLE 2A - SCULL DIMENSIONS (FIGURES 5 & 6) - IMPERIAL UNITS

CODE	DIMENSIONAL DESCRIPTION	DIMENSION	TOLERANCE
<u>MANDATORY DIMENSIONS</u>			
A	Over-sleeve width parallel to blade tip	2"	- 0 + ³ / ₁₆ "
B	Over-sleeve width at right angles to blade tip	2"	- 0 + ³ / ₁₆ "
C	'Flat' distance parallel to blade tip	1½"	± 1/8"
D	Height of button from loom	1"	± 1/8"
<u>RECOMMENDED DIMENSIONS</u>			
E	Inboard length - Bow Sculls - Stroke Sculls	2' 2" 2' 3½"	± ¼" ± ¼"
-	Overlap (looms horizontal and in line)	7"	± 1"
F	Outboard length - Bow sculls - Stroke sculls	7' 0¾" 7' 1¼"	± ¼" ± ¼"
G	Overall length - Bow Sculls - Stroke Sculls	9' 2¾" 9' 4¾"	± ½" ± ½"
-	Nominal 'Outboard: Inboard' ratio - Bow sculls - Stroke sculls	3.26:1 3.10:1	- -
H	Blade length (all sculls)	25"	± 1"
J	Blade tip (all sculls)	6"	± 1/8"

CONSTRUCTION OF SKIFFS

TABLE 2B - SCULL DIMENSIONS (FIGURES 5 & 6) - METRIC UNITS (cm)

CODE	DIMENSIONAL DESCRIPTION	DIMENSION	TOLERANCE
	<u>MANDATORY DIMENSIONS</u>		
A	Over-sleeve width parallel to blade tip	5.08	- 0 +0.48
B	Over-sleeve width at right angles to blade tip	5.08	- 0 +0.48
C	'Flat' distance parallel to blade tip	3.81	± 0.32
D	Height of button from loom	2.54	± 0.32
	<u>RECOMMENDED DIMENSIONS</u>		
E	Inboard length - Bow Sculls - Stroke Sculls	66.04 69.85	± 0.64 ± 0.64
-	Overlap (looms horizontal and in line)	17.78	± 2.54
F	Outboard length - Bow Sculls - Stroke Sculls	215.27 216.54	± 0.64 ± 0.64
G	Overall length - Bow Sculls - Stroke Sculls	281.31 286.39	± 1.27 ± 1.27
-	Nominal 'Outboard: Inboard' ratio - Bow sculls -Stroke sculls	3.26:1 3.10:1	- -
H	Blade length (all sculls)	63.50	± 2.54
J	Blade tip (all sculls)	15.24	± 0.32

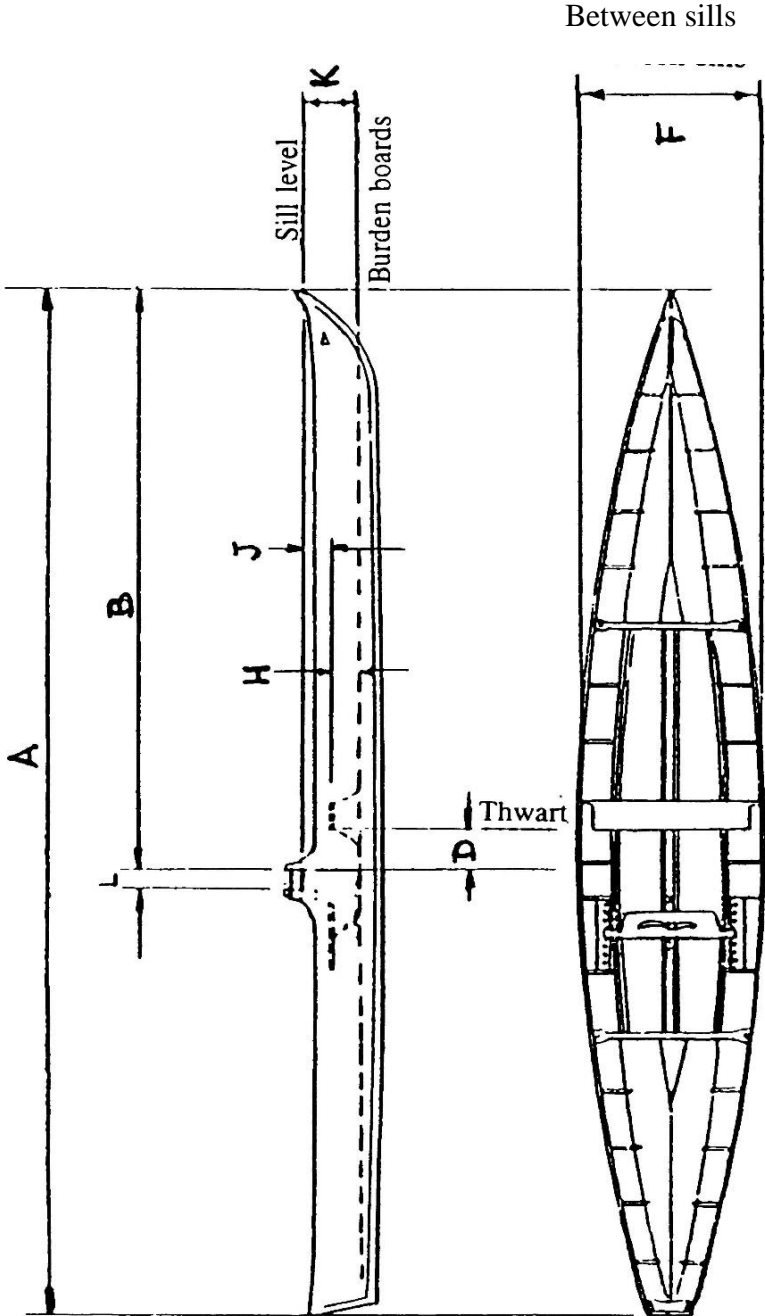

Figure 1 - SINGLE SKIFF

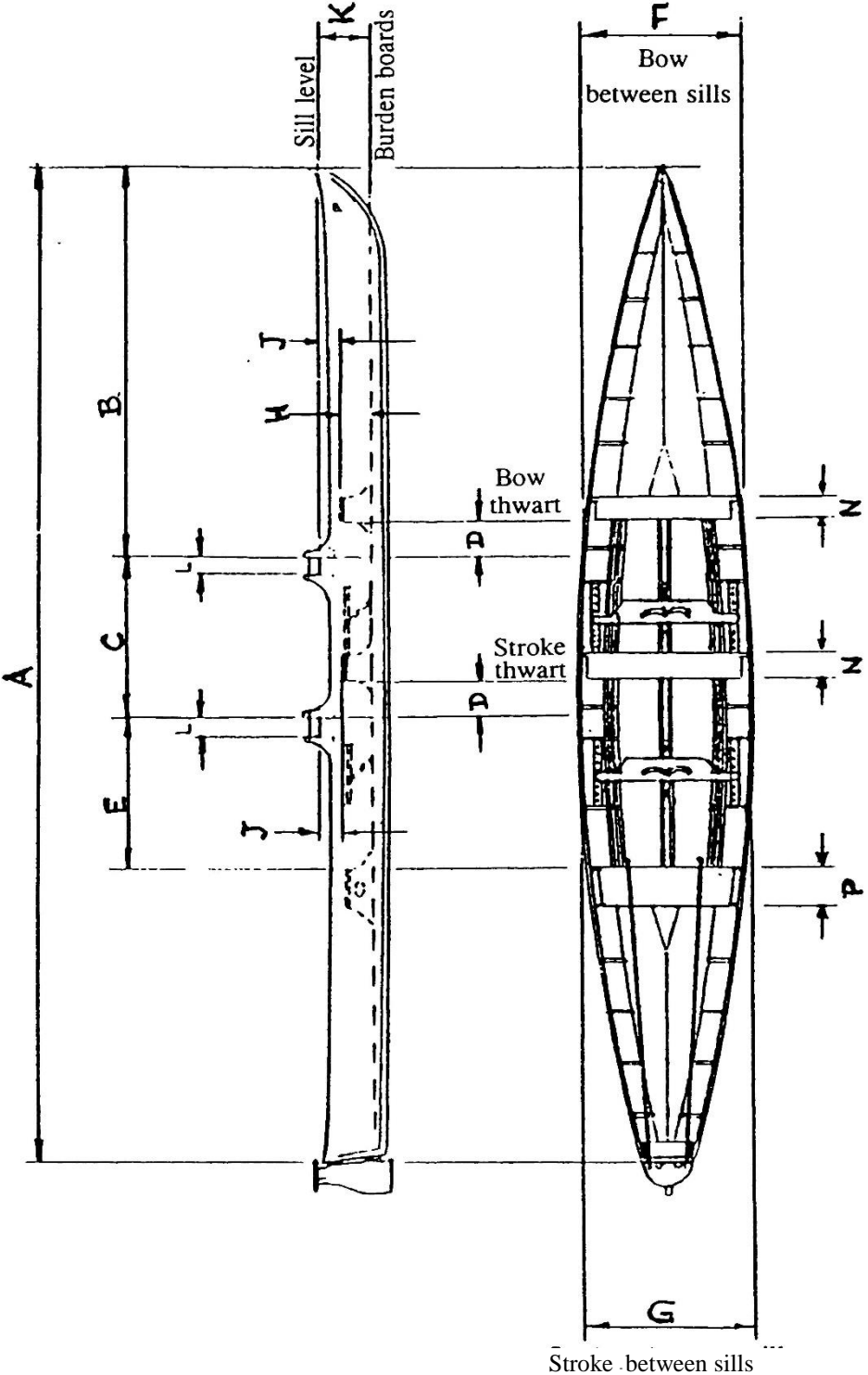

Figure 2 - DOUBLE SKIFF

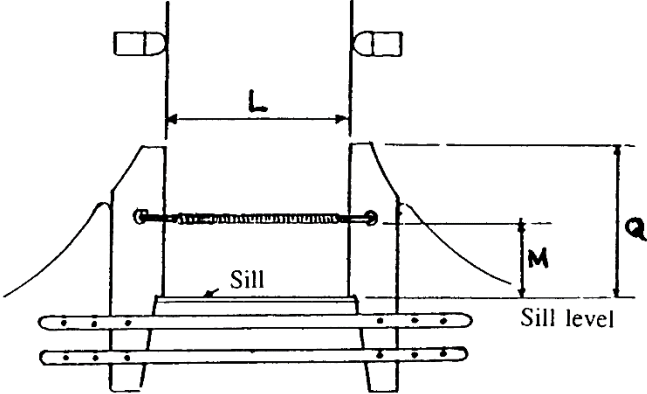

Figure 3 - THOLE PINS

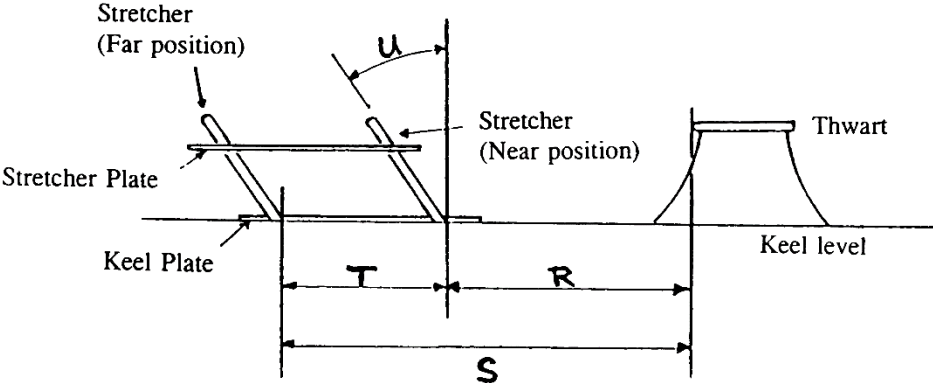

Figure 4 - STRETCHER

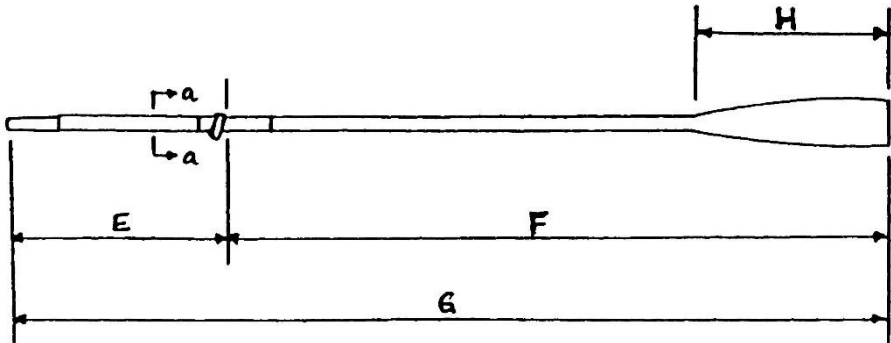

Figure 5 - VIEW OF STROKE SCULL FROM BOW

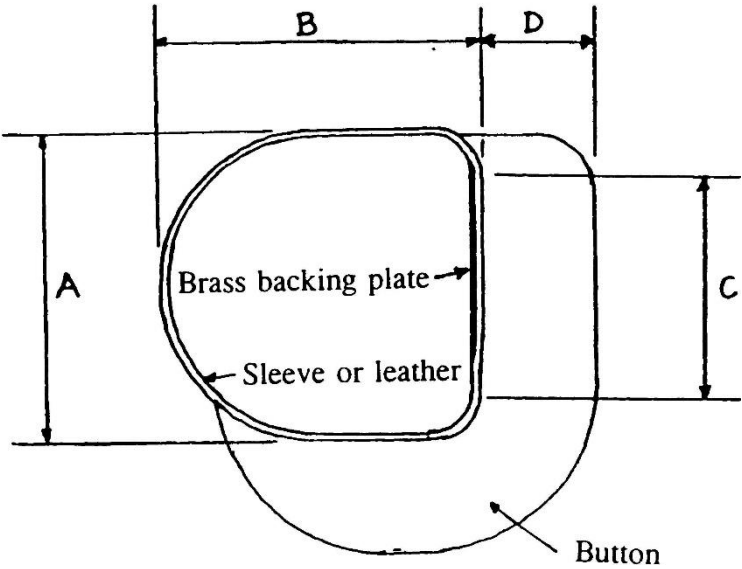

Figure 6 - VIEW OF SCULL CROSS SECTION FROM 'a-a'

RULES OF RACING

INTRODUCTION

These Rules relate to racing in skiffs at competitions which may be regattas or processional races. They do not cover racing in any other form of craft or in skiffs propelled by means other than sculls; nor do they cover races, whether in skiffs or not, included in 'Rag' regattas.

'**Regatta**' is defined as a group of one or more events managed by one Organising Committee.

'**Processional Race**' is defined as one in which boats are started at intervals of time or distance and of which the result is determined in an order based on elapsed time, or on bumping or overtaking.

'**Race**' is defined as any heat, repêchage or final in an event.

'**Event**' is defined as a race or series of races leading to a final decision in any category of racing and includes a category of racing within a Processional Race.

The term '**crew**' is deemed to include the scullers and coxswain in double sculling and the sculler in single sculling.

'**Circulation Pattern**' is defined as the compulsory directions of travel in various areas and lanes in and around a course that are available for competitors' use during racing and practice on the water.

'**Not Sculled Out**' is a verdict used when one or more crews in a race fail to continue racing throughout the course to the finish.

A '**foul**' is defined as any collision or contact between boats, sculls or persons in the same race.

'**Interference**' is defined as conduct by a crew that may impede the progress of an opposing crew that is on its proper course.

<u>Section</u>	<u>Subject</u>
A	General
B	SRA Competition Conditions and Entries
C	SRA Competition Regulations
D	Categories of Events
E	Status Points for Competitors
F	Race Regulations
G	Disputes and Disciplinary Procedures
H	Processional Races
J	Safety Regulations

RULES OF RACING

SECTION A - GENERAL

- A1 The Rules of Racing adopted by the SRA shall be observed.
- A2 The organization, control and safety of a competition under these Rules shall be the responsibility of the committee organising the competition which is identified as the Organising Committee..
- A3 An Organising Committee shall appoint officials to carry out the duties specified in these Rules. With the exception of processional races, no one shall act as an umpire who is not a qualified SRA umpire or the holder of a valid BR Umpires Licence or an SRA probationary umpire acting under the supervision of a qualified umpire.
- In processional races probationary umpires are allowed to act as umpires without being under the supervision of a qualified umpire, and unqualified persons (race monitors) may act as umpires but without the power to disqualify. Race monitors should have an adequate knowledge of the rules of the event concerned, but they should be used only if there are not enough qualified or probationary umpires available.
- A4 An Organising Committee shall state in its programmes and official notices that the competition is to be held in accordance with the Rules of the SRA.
- A5 No competition shall be held under these Rules unless its date, place and conditions have been approved by the Committee of the SRA. The Committee may refuse to approve a date that has not been submitted in accordance with the timetable specified annually by the Committee of the SRA.
- A6 If a competition does not take place on the agreed date, through exceptional or unforeseen circumstances, the Organising Committee may hold it on another date with the approval of the Committee of the SRA.
- A7 The Organising Committee shall forward the results of the racing to the Hon. Secretary of the SRA, or an officer of the SRA delegated to record points, within seven days of the competition. These results shall include, for each event in the programme, the names of the winners and their clubs, the number of entries, and the number of scratchings. The results shall make clear any events that do not qualify for the Ormiston, Junior Pennant or Veteran Pennant competitions. A properly marked-up programme would suffice.
- A8 All questions not specifically covered by these Rules shall be decided by the Organising Committee, which shall take care to ensure that no breach of them arises from the imposition of local conditions.

EXPLANATORY NOTES AND COMMENTS

- A5 *The SRA Committee maintains a five-year regatta calendar on a rolling basis, a copy of which is sent to all affiliated clubs and regattas. If any club or regatta requires changes to its programme, it is essential that the Hon. Secretary be informed of such before the autumn Committee meeting when, to enable adequate publicity to be given, the calendar for the ensuing year is confirmed.*
- A6 *To expedite the approval of a new date, the Committee may empower the Hon. Secretary to give approval if he or she considers the new date will not raise any problems.*
- A8 *If an Organising Committee decides to impose special conditions, whether connected with qualifications for entry or affecting the conduct of a race, care should be taken to include the particulars both in the entry form and in the programme.*

SECTION B - SRA COMPETITION CONDITIONS AND ENTRIES

B1 Notice of a regatta or processional race shall include:

- (a) Place, date and time of the competition
- (b) The categories of events.
- (c) Special restrictions or conditions, whether or not affecting classification of competitors.
- (d) The amount of the entry fees.
- (e) The length and location of the course.
- (f) The date and time at which entries close.
- (g) The address for entries and correspondence.

A copy of the notice of the event shall be forwarded to the Hon. Secretary of the SRA simultaneously with the distribution to clubs.

B2 The entry form for a competition shall include:

- (a) The name of the club entering.
- (b) The names and, where appropriate, date of birth and weight of competitors.

The names of the competitors shall be set out in the order of sculling, beginning with bow, who shall be designated 'Number 1'.

The following form of certificate shall appear on the entry form:

'I certify that all competitors named and any substitutes who may be introduced are/will be members of this club, or of the clubs shown against their names, and are eligible to compete in the events for which they are entered.'

An entry shall not be valid unless the entry form has been duly completed and signed.

B3 Entries shall close at least three clear days before the date of the competition.

No official of the Organising Committee shall divulge any entry, or report the state of the entry list, until such list is closed.

B4 No person shall be entered more than once for the same event at a competition.

B5 An Organising Committee may investigate any questionable entry and may return or annul an entry at any time without giving a reason

B6 If only one crew is entered for any event, the Organising Committee shall cancel the event and refund the entry fee, or, if the crew involved agrees, they may transfer the entry to a handicapped event or another event for which the crew is eligible. This Rule shall not apply to a Skiff Championship event. If the event is a category of racing within a processional race, the Organising Committee shall not refund the entry fee but may, if the crew involved agrees, transfer it to another category of racing for which it is eligible.

B7 No later than three days before the competition, the Organising Committee shall send a listing of each competitor's first race time to the representative of the competitor's club. Competitors should be instructed to be present and ready to boat 20 minutes before their race time. For processional races the start order by division may be sent, and competitors should be given the time of any pre-race briefing

B8 A crew must scull the course in order to be eligible for a prize or points.

If all but one crew withdraw from an event without competing the award of any status or competition points to the remaining crew is as defined in the rules of the competition. [E3, Ormiston 4.1 (b). Junior Pennant, Veteran Pennant].

If a crew competes and then withdraws from an event, it is deemed to have competed in the event.

B9 The Organising Committee may, if notified at least 30 minutes before the official race time, permit a substitute to take the place of any one sculler of a doubles crew named in the entry provided that neither the substitute nor the original crew member has

RULES OF RACING

already raced in the event. The substitute need not be a member of the club of the original crew member.

- B10 When a coxswain is not available, a person whose name has not been entered and who has not already coxed or sculled in the event may, with the consent of the Organising Committee, act as a coxswain. The name of the replacement coxswain must be notified to the Organising Committee at least 30 minutes before the official start time of the crew's first race.
- B11 The Organising Committee may permit a crew that has already raced to race with a replacement cox if the original cox becomes unavailable through exceptional and unforeseen circumstances and provided the Racing Committee and remaining competitors in the event are in agreement.
- B12 Objections to the qualifications of a competitor shall be made to the secretary of the regatta or processional event and confirmed in writing as soon as possible. The Organising Committee may withhold or withdraw prizes until the outcome of any investigation is announced.

EXPLANATORY NOTES AND COMMENTS

- B2 *It is advisable to require as a condition of entry that entry fees shall accompany the entry, and that entries by telephone shall be confirmed on the proper entry form by a specified time. Entries by fax or E-mail are acceptable. Action under Rule B5 against competitors failing to comply would be appropriate.*

The Rule does not debar composite crews, competing under the titles of their clubs, provided that the entry form is duly completed. The entry in such cases must be made by an officer of one of the clubs concerned. The names of all the clubs must be included in the title under which the crew will race.

- B6 *If a crew is the only competitor in a final, the following four scenarios illustrate the outcomes according to different circumstances*
- 1 There is only one entrant - the race is cancelled or the entrant transferred to another event*
 - 2 There are more than one entrants, but all but one withdraw before racing - the competitor may row over for a prize, but earns no point in any competition*
 - 3 There are more than two entrants and a crew competes in and wins a heat, but its opposition (having a bye or winning a heat) withdraws before final - the remaining competitor wins prize, earns points and does not have to row the course again*
 - 4 There are more than two entrants and a crew has a bye to final, but winner of the other heat withdraws - the remaining competitor has to row over to win prize and earn points*
- B7 *This Rule is designed to ensure that clubs have adequate notice of times of racing to enable them to plan accordingly in the interest of competitors.*
- B10 *A coxswain who is not a member of the club or clubs of the remainder of the crew may be used, but the crew then forfeits any right to gain Ormiston, Veteran Pennant or Junior Pennant points.*

SECTION C – SRA COMPETITION REGULATIONS

- C1 An Organising Committee shall not offer any form of money or value prize without obtaining the prior written authority of the Hon. Secretary of the SRA. Any club or regatta offering such a prize without prior approval shall be liable to be penalized, and such prize, if awarded, shall be returned forthwith. Clubs, regattas or competitors giving, offering or accepting any unauthorized money or value prize from any source shall be liable to suspension from the SRA or from competition as appropriate.
- C2 Trophies shall be deemed to be awarded to the successful competitors unless specified otherwise.
- C3 The design, dimensions and construction of skiffs shall be as specified by the SRA. See the section entitled ‘Construction and Dimensions of Racing Skiffs and Sculls’.
- C4 Races shall take place in matched skiffs, except
- (a) for processional races,
 - (b) in exceptional circumstances when the Organising Committee may allow unmatched skiffs.
- C5 No competitor shall make use of any substance capable of modifying the natural properties of water.
- C6 Women may not compete in men’s events or vice versa except as coxswains.
- C7 Every competitor shall wear complete clothing. Scullers shall wear a sleeved jersey which shall show the racing colours of the club they represent.
- C8 The Organising Committee shall appoint a Race Committee of three qualified umpires and shall nominate a chairman from among them who shall be responsible to the Organising Committee for the applications of the Rules of Racing at the competition.
- The Race Committee shall take any decisions on the conduct of racing that are not in the province of an officiating umpire, and shall hear any protests or complaints to or from the Organising Committee.
- The race umpire is responsible for the conduct and outcome of the race.
- C9 The Organising Committee shall appoint a suitably qualified person or persons as Raft Marshall who shall:
- (a) supervise the crews’ embarking and disembarking points with full regard to safety.
 - (b) ensure that all relevant Rules are observed including the following
 - (1) the construction and serviceability of boats
 - (2) the matching of boats
 - (3) the composition and dress of crews,
 - (4) Weight rules appertaining to the carrying of dead-weight by coxswains, and to Lightweights.
 - (c) ensure that crews know the circulation pattern and their station before proceeding to the start.
- The Raft Marshall shall endeavour to ensure that the race schedule is adhered to by effective management of boats and crews.
- C10 The Organising Committee shall provide a programme for competitors and officials, listing the officials, the crews, the schedule of events and the specific competition rules. The programme shall contain the handicaps for crews in Veteran and other handicapped events.
- The Organising Committee shall provide to relevant parties any changes or corrections to programme information that may arise during the course of the regatta.
- C11 Specific rules for the organisation of Processional Races are provided in Section H (Paras H1, H2, H3, H4)

EXPLANATORY NOTES AND COMMENTS

- C2 *Organising Committees should obtain receipts for trophies, specifying the items (such as plinth, lid, cases, and keys) which accompany them, and include instructions for their return. The receipts should also include an undertaking by the recipient to be responsible for their safe custody and return, and the name and address for correspondence. An Organising Committee may, however, decide to retain its trophies after presentation to the winners*
- C7 *Article 3 of the SRA Constitution refers.*
- C8 *The Race Committee shall act as the authority on the application of the Rules of Racing and should be ready to advise on any aspect of the running of the competition where the Rules have an impact, or where there is any need to consider safety or 'fair conditions' for racing. During the competition, the Race Committee should always be available to any umpire for support and advice, and to receive suggestions for the improvement of the conditions for racing. The Race Committee's powers include:*
- (a) Suspension of racing for safety reasons under Rule J7.*
 - (b) Alterations to the course following changes to stream or wind.*
 - (c) Action, as the representatives of the Organising Committee, of disciplinary measures under Rules G8 and G9.*
- The race umpire is responsible for the race, and his verdict cannot be overturned. However, in hearing a protest taken to the organizers, the Race Committee may draw the attention of the race umpire to facts, circumstances and consequences of which he may not have been fully aware; the umpire may then reconsider his verdict if he believes this to be appropriate.*
- C9 *The Organising Committee must ensure that a suitable weighing machine is provided.*
- The Raft Marshall may mark the boats with the colour of their station.*
- The Raft Marshall may remind competitors that under F9, a race may be started without reference to absentees, and should notify the Umpire if a crew is wilfully absent at the time the race is due to start.*
- C10 *If there are any missing or incorrect handicaps encountered in the programme during racing, it is the responsibility of the Organising Committee to calculate them*

SECTION D – CATEGORIES OF EVENTS

- D1 Qualification under these Rules is independent for single sculling, double sculling, and mixed-double sculling.
- D2 An Open event shall be one for which any competitor eligible under the general conditions and the qualifications for that particular event may enter.
- D3 A Closed event shall be any one of the following, and shall not be subject to these Rules other than Rule D1:
- (a) Private matches arranged solely by agreement among the clubs or competitors concerned.
 - (b) Events open only to members of one club.
 - (c) Invitation events, i.e. events restricted to competitors specified by the organizers.
- D4 A Status event is an open event the winning of which may affect a competitor's points status, and is any open event other than those defined in Rule D10. A competitor's status points shall relate to those held at the beginning of a regatta
- There are five levels of status events
- (a) Senior
 - (b) Higher
 - (c) Intermediate
 - (d) Novice
 - (e) Entrant
- ..
- D5 Senior events are open to any sculler.
- D6 Higher events are open to scullers whose number of status points is less than 12, or to double scullers whose combined number of status points is less than 24.
- D7 Intermediate events are open to scullers whose number of status points is less than 8, or to double scullers whose combined number of status points is less than 16.
- D8 Novice events are open to single scullers whose number of points is less than 4, or to double scullers whose combined number of status points is less than 8.
- D9 Entrant events are open to scullers who have zero status points unless they have achieved a total of 8 or more points in other categories.
- D10 Non-Status events are open events and shall be:
- (a) Veteran events.
 - (b) Restricted Veteran events
 - (c) Junior events
 - (d) Handicap events
 - (e) Lightweight events
 - (f) The Tiny and Nancy Knight races
 - (g) Relay events
 - (h) Events in which the competitors are allocated to crews by the organizers
 - (i) Events specifically advertised as 'Non-Status', and other events held under special conditions, subject to previous approval in each case by the Hon. Secretary of the SRA

The winning of non-status events does not add to a competitor's status points except that a win in an event under items (a) to (f) will affect a competitor's qualification for Entrant events (see section e2 (b))

- D11 Veteran events are open to any sculler who has attained the age of 40 years before 1st January of the current year and has not won a Senior status event in that event category in the current year. It is mandatory for the year of birth to be inserted on the entry form. (See the section entitled 'Veteran Racing'.)

Novice Veteran events are open to any sculler meeting the veteran age criteria who has less than 4 status points.

RULES OF RACING

- D12 Restricted Veteran events are processional events open to Veteran scullers and crews having an age or combined age above the minimum limits defined in or derived from Rule D11. It is mandatory for the year of birth to be inserted on the entry form. (See the section entitled ‘Veteran Racing’)
- D13 Junior events are open to competitors aged 12 or over and under 18 on the day of racing. It is mandatory for the full date of birth to be inserted on the entry form
- D14 Handicap events are open to all scullers, the handicap being based on the status points of crews. Handicaps will be based on the average status points in a boat subtracted from 13 and converted to seconds.
- If the course is 500 metres or less, the handicap difference shall be reduced by one second for every full five seconds difference between the handicaps of the two crews. If the course is 700 metres or above, then the handicap difference shall be increased by one second for every full five seconds difference between the handicaps of the two crews.
- D15 Lightweight events are open to scullers whose weight does not exceed 72.5 kg (men) or 59 kg (women). The average weight of a doubles crew (excluding coxswain) shall not exceed 70 kg (men), 63.5 kg (mixed), or 57 kg (women). Lightweight competitors shall be weighed wearing their racing kit (Rule C6) before their first race of the regatta.
- D16 An Organising committee may transfer to another event of appropriate category a crew whose classification changes between the date of entry and the beginning of the event. If the crew does not wish to accept the transfer, the entry fee shall be refunded.
- D17 There is no classification of Coxswains and they shall sit on the coxswain’s thwart.
- The minimum weight for Coxswains shall be 50 kg,
- Coxswains who weigh less than 50 kg shall carry dead-weight to make up the deficiency, and this shall be carried beneath the coxswain’s thwart.
- Coxswains shall be weighed before their first race in the clothing they expect to wear in the event, inclusive of any buoyancy aid.

EXPLANATORY NOTES AND COMMENTS

- D9 *For example a competitor who has achieved 8 points in a Doubles category may not compete as an Entrant in a Singles event, even if they have zero points in Singles events*
- D17 *It is not necessary to weigh coxswains about whose weight there can be no reasonable doubt.*

RULES OF RACING

SECTION E – STATUS POINTS FOR COMPETITORS

- E1 The acquisition of status points is independent for single sculling, double sculling, and mixed-double sculling. [D1]
- E2 A sculler begins with zero status points, with the exceptions that
- (a) a sculler who has won a BR event during the previous 10 years automatically begins with five points.
 - (b) a sculler who has only won a BR event more than 10 years previously, or any non-status skiffing event under section D10. (a) to (f) - ie a Veteran, Junior, Handicap, Lightweight or Tiny/Nancy Knight event - will automatically begin with one point
- E3 Scullers are awarded a point for a win in a status event in which two or more crews compete, unless they already have 13 points.
- E4 A sculler winning a Skiff Championship event attains 13 status points in the category of that event.
- E5 Changes to points shall take effect at the end of the day's racing.

EXPLANATORY NOTES AND COMMENTS

- E2 *In order to adjust the points when the non-qualifying rule was removed in 2010, the following conversions were agreed:*

<i>Old</i>	<i>New</i>	<i>Old</i>	<i>New</i>
0	0 or 1 depending on eligibility for entrant.		
0.33	2	4.33	9
0.66	2	4.66	9
1	3	5	10
1.33	4	5.33	10
1.66	4	5.66	10
2	5	6	11
2.33	6	6.33	11
2.66	6	6.66	11
3	7	7	12
3.33	8	7.33	12
3.66	8	7.66	12
4	9	8	13

In order to assimilate scullers into the new mixed-double classification, the following ruling was made at a Committee meeting held on 8th June 1983.

'A sculler's existing doubles status on 1st January 1983 will be the status level that a sculler assimilates into the new mixed-double classification. It is irrelevant whether the sculler has 1 or 2 Junior-Senior wins to his credit, the sculler concerned starts at Junior- Senior level and is entitled to win his full quota of Junior-Senior wins before becoming a Senior.' Converting this to the points system, the number of points allocated are as follows

STATUS OF SCULLER IN DOUBLES AT 1st JANUARY 1983

STATUS POINTS

<i>Senior win</i>	<i>13 points</i>
<i>Senior no wins</i>	<i>13 points</i>
<i>3 Junior-Senior wins</i>	<i>12 points</i>
<i>2 Junior-Senior wins</i>	<i>11 points</i>
<i>1 Junior-Senior win</i>	<i>10 points</i>
<i>1 Junior win</i>	<i>7 points</i>
<i>No Junior wins</i>	<i>5 points</i>

Anyone who, pre-January 2010, had reached Senior status but had not won at that level, will regress by one full status point, thus bringing them back to Higher level

SECTION F - RACE REGULATIONS

General

F1 These Regulations shall be so applied as to ensure that all competitors race under fair conditions, but considerations of safety shall take precedence at all times. Those regulations marked with an asterisk do not apply to processional races.

F2* Each crew shall be assigned a lane or station, which shall be the crew's designated water for the duration of the race.

A boat's proper course shall be defined as that which it must follow from start to finish while remaining on its own water on the prescribed course.

Umpires

F3* Umpires shall be appointed by the Organising Committee to be responsible for the conduct of each race or for the conduct of a group of races through a section of the course (bank umpiring).

A probationary umpire may act as a race or bank umpire if under the supervision of a qualified umpire, but the latter shall have ultimate responsibility for the conduct of the race or part of the race.

F4* Starters and aligners may be appointed to start or assist with the start, and they shall be umpires or probationary umpires under supervision, but the race umpire may act as starter.

F5* Race and bank umpires, starters, and aligners shall each be provided with a red flag, a white flag and a megaphone (electric if possible) or loud-speaker equipment, and a regatta programme.

F6* A launch used for umpiring shall be so constructed as to enable the umpire to carry out his duties properly.

F7* If the race is umpired from the bank,

- (a) adequate communications between umpires shall be provided.
- (b) Umpires should also wear distinguishing armbands and be provided with a position from which they can clearly see each race in the portions of the course for which they are responsible, and as far as possible be seen by the competitors.
- (c) Umpires shall be located at distances that allow any warning to be heard by the competitors whilst under their jurisdiction.
- (d) A co-ordinating umpire shall be available to overhear all communication between umpires and to be in communication with the judge.
- (e) All decisions shall be taken by the umpires and shall be given to the judge by the co-ordinating umpire.

F8* Umpires shall from time to time during the regatta inspect the course or portion of the course for which they are responsible and take appropriate remedial action where necessary.

The Start

F9* A crew shall be at the start two minutes before the time of the race.

The start may take place without reference to absentees.

Any crew late arriving at the start and permitted to race may incur a penalty of one Official Warning at the discretion of the umpire and/or starter.

F10* If there is only one crew in a race, the Organising Committee shall decide whether the crew shall be required to scull over the course in a race other than a final.

RULES OF RACING

F11* The umpire, starter or aligner shall prepare the crews for the start with a minimum of delay.

An aligner, if provided, shall indicate that the crews are aligned by raising a white flag.

F12* When the crews are at their starting positions the starter or umpire shall announce any Official Warnings that may have been given against any crews in the race, including any awarded under Rule F9.

He shall then name the crews and tell them how they will be addressed during the race.

(a) The starting and timing procedure for non-handicapped events shall then be as follows:

The starter shall say 'Get ready',

The starter shall say 'Attention', at which time he shall slowly and deliberately raise the red flag

The starter shall then lower the flag quickly to one side with the command 'Go'.

If an aligner is present, the starter shall check that he has the white flag raised before the 'Attention' command is given.

(b) The starting and timing procedures for handicap races (including veteran) shall be as follows:

The starter shall declare the handicaps to be applied and explain the starting method, and ensure that any stake-boat persons know the order of starting.

The starter shall then conduct a normal start but at the word 'Go' only the crew(s) with the greatest handicap will start.

After the first 'Go' the starter shall, using a stopwatch, count up the handicap time in whole seconds ending with the word 'Go' when the second crew(s) will start, and continue thus until all crews have started. The red flag shall be raised and dropped for each start.

For example, in a three-crew race where the second and third crews have, respectively, a 5 second and 9 second handicap relative to the first crew, the starter shall say 'Go, one, two, three, four, Go, six, seven, eight, Go'. The counting shall be made audible to all crews involved, and the crews remaining at the start after the first 'Go' shall maintain themselves in a state of readiness for subsequent starts.

The elapsed time of the winning crew shall be the time from the first 'Go' to the finish less any starting handicap applicable to that crew.

F13* If the umpire, starter, or aligner considers the start false, he shall recall the crews to the start by saying 'Stop' and waving the red flag.

The decision to recall the crews shall be made before they have completed 50 metres of the course.

The crew or crews causing the false start, or deliberately sculling on after the race has been stopped, shall be given an Official Warning by the starter or umpire.

In the event of a false start by any crew in a handicap race, the normal 'false start' procedures shall apply except that the 50 metre proviso shall not apply.

F14* If a crew refuses to start again or incurs two Official Warnings, the umpire shall disqualify it from the event.

The Race

F15* During the race, each boat shall remain on its proper course; it shall not encroach on the courses of other competing boats, nor interfere with them, nor prevent them from following their proper courses.

A crew continuing out of its proper course after due warning does so at its peril, and if it derives any advantage from so doing

RULES OF RACING

may be disqualified by the umpire.

F16* The umpire shall be the sole judge of a boat's proper course and shall decide all questions relating thereto.

F17 The umpire may call the attention of a crew to its steering only if

- a) the crew is about to interfere with or foul another crew, or
- b) disqualification is possible under Rule F15, or
- c) there is danger of a collision with a temporary or permanent obstruction on or off the course.

F18* When the umpire in a launch warns a crew, he shall

- a) raise a white flag vertically above his head,
- b) name the crew
- c) point the flag at arm's length in the direction in which the crew is to move.
- d) when the crew has responded, drop the flag smartly to the side out of sight.

When an umpire on the bank warns a crew he shall

- a) raise a white flag vertically above his head,
- b) name the crew
- c) audibly instruct the crew in which direction it is to move.
- d) when the crew has responded, drop the flag smartly to the side out of sight.
- e) inform the next umpire of the instructions that he has given.

When the umpire stops the race, he shall wave a red flag and give the order 'Stop'.

When the umpire stops a crew but not the race, he shall raise the white flag vertically, name the crew and give the order 'Stop'.

When the umpire warns a crew because of the danger of collision with an obstruction, he shall raise the white flag vertically, name the crew, and announce, 'Obstruction, look ahead'.

F19 Crews shall be responsible for their own steering and the umpire shall ensure that crews are not followed or paced during the race by other racing boats, nor receive any advice or instructions. No use shall be made of a megaphone, radio equipment or similar apparatus to encourage a crew from outside the boat.

A crew receiving any extraneous assistance risks an Official Warning or disqualification, and any following or pacing crew risks the same penalties.

F20 Definitions of a foul and interference are given in the Introduction to the Rules of Racing

F21 If the umpire detects interference, he shall warn the offending crew, but no crew shall be disqualified for interference unless it has been warned.

F22* Following a foul or repeated interference, the umpire may:

- (a) Allow the race to continue; for example if the offence, in the opinion of the umpire, will not affect the outcome of the race.
- (b) Stop the race and restart it, either from the start or the point of stoppage; for example, if the offence occurred in neutral water.
- (c) Disqualify an offending crew and allow the race to continue if more than one crew remains in the race.
- (d) Stop the race, disqualify an offending crew, and restart the race, either from the start or from the point of stoppage.

RULES OF RACING

- (e) Determine the finishing order; for example, if the offence occurred near the finish line.
- (f) Adopt a combination of these actions.

F23* A crew shall abide by its own accidents except where:

- (a) Damage to equipment is sustained within 50 metres of the start, or
- (b) Damage is sustained by interference from an outside agency.

In such cases the umpire may order the race to be re-scull. The Organising Committee shall decide the time of the re-scull. However, if it is subsequently discovered that no damage has been sustained, the crew claiming damage is liable to disqualification.

The Finish

F24 Judges shall be appointed to decide the order in which boats pass the finish line, and may be required to determine the distance between them. If necessary they may inspect any official photographic records of the finish.

There shall be a chief judge who shall be an umpire.

F25* In the case of a race umpired from a launch, the umpire shall indicate to the judges by raising his white flag when all crews have crossed the finish line that the race is in order and no protest has been lodged.

If the race is not in order, the umpire shall raise his red flag.

In the case of a bank-umpired race the co-ordinating umpire shall indicate to the judges whether or not the race is in order.

F26* The judges shall declare the race results. If a red flag has been given, the judges shall pay attention to any declaration of the umpire.

F27 A crew has completed the course when the bows of the boat cross the finish line.

If a competitor, other than a coxswain, falls out of the boat, the crew may still be placed.

If a coxswain falls out of the boat, the crew shall be deemed not to have completed the course; the verdict shall be 'Not Sculled Out'.

F28* If two or more boats are judged to cross the finish line simultaneously, the Organising Committee shall arrange a re-scull. If a crew refuses to re-scull, it shall be disqualified.

In the event of a dead heat in a handicapped race, if the race is re-sculled over a part (normally a half) course, the original handicap difference shall be reduced accordingly.

EXPLANATORY NOTES AND COMMENTS

F2 *The principle behind this Rule is that every competitor should have an equal chance of winning. Allowance may have to be made for unequal stream. A boat is not entitled to leave its own proper course in order to try to deprive an opponent of such advantages as properly belong to that opponent.*

F5 *It is desirable that an umpire should provide for his own use a megaphone and two flags, one red and one white, each measuring 16 inches x 12 inches (406mm x 305mm). An umpire should also have available a stop-watch. An umpire should inform the competition secretary in advance if he requires the Organising Committee to provide any such equipment.*

F6 *The intention of this Rule is that the umpire's eye level should be sufficiently high for him to obtain an adequate view of the crews and course, and that he and his flag signals should be easily seen by the competitors. To this end a suitable launch should have support at chest or waist level for the umpire, and be stable, manoeuvrable, adequately fast but of low wash characteristics, and be driven by an experienced driver.*

RULES OF RACING

- F8 Before starting his duties, an umpire must thoroughly familiarize himself with the course, obtaining any necessary information about local conditions and instructions issued by the Organising Committee.*
- The umpire must ensure that the course continues to provide safe and fair racing on all stations as conditions change and notify the Organising Committee if the course need to be corrected.*
- An umpire should accept the positions of stake-boats 'as found' but should be prepared to notify the Organising Committee of any movement of the stake-boats he may notice. In the event of one or more of the stake-boats clearly being out of position the umpire is entitled to refuse to use it and make such 'on-the-spot' arrangements as he may think fit and proper depending on all the circumstances.*
- F9 'At the start' means on the stake-boat or on the start-line. Rule F9 should always be applied, but an umpire or starter should satisfy himself that an absent crew is not being delayed by causes outside its control.*
- F12 The starter should ensure that any affected crews understand that an Official Warning counts as a false start, and so a false start in the race will eliminate them. He shall ask for an acknowledgement from any crews so named. Official Warnings may be given by umpires or the Race Committee for a variety of infringements of the Rules; an Official Warning from either of these sources shall be taken into account by the starter.*
- The start shall be given by the 'Get Ready' – 'Attention' – 'Go' sequence given in the Rule. At 'Get Ready', the crews must get ready to race. At this stage crews may indicate that they are not ready by a raised hand from the coxswain, or verbally in the case of a single sculler. If a crew indicates that it is not ready, it is essential that it takes positive action to be ready as quickly as possible. If the starter believes that one or more crews are delaying the start through incompetence or without good reason, or if wind conditions make it too difficult for all crews to achieve simultaneous alignment down the course, he shall indicate his intentions to proceed with the start by the words 'Hands Down', or verbally in the case of single scullers.*
- If, or when, there is no indication that any crew is not ready, or the starter has indicated his intention to proceed, the starter shall continue with the start. (If there has been a delay, the starter may repeat 'Get Ready' to recall crews' attention to the start procedure.) The starter shall slowly and deliberately raise a red flag, at the same time saying 'Attention'. At this stage, the starter shall be in full control of the start and shall start the race by dropping the flag smartly to the side, at the same time saying 'Go'.*
- Between 'Attention' and 'Go', crews must be ready to start on the start order; crews shall not be able to delay the start procedure after the 'Attention' instruction is given, and must start when the flag is dropped and the 'Go' is given.*
- If, after raising the flag and saying 'Attention' the starter is not satisfied that all is well, the red flag shall be lowered slowly and the starter shall say 'As you were'. The start sequence shall then begin again from 'Get Ready'.*
- There shall be a positive and deliberate pause between 'Attention' and 'Go'. The pause between the raising of the red flag and the start command shall be variable.*
- F13 A start is 'false' if any boat leaves its starting position before the word 'Go'. It is not 'false' if a boat fails to start when the word is given, unless some unforeseen incident prevents the starting signal from being seen or heard. The point 50 metres from the start should be clearly marked. If both umpire and starter are present, the umpire has the responsibility of giving an Official Warning.*
- F17 A temporary obstruction on the course may be another boat, an object in the water, or any other item that should not be there including swimmers or animals. In these circumstances the umpire should warn the crew in plenty of time so that the crew may take avoiding action; he may, in this case only, give steering advice to the crew. The umpire also has the option of stopping the race and declaring a verdict, or re-sculling the race from the start or the point of stoppage.*
- In the case of a similar temporary obstruction off the course, whether legitimately there or not, a crew in danger of collision should be warned to return to the course or, if necessary, stopped. The race would not be stopped.*
- A permanent obstruction, on or off the course, could be any structure that may provide a risk of damage or injury to boat, equipment or crew, and may include the bank, staging, moored boats or heavy buoys. The umpire should delay warning a crew for as long as possible, consistent with safety, to give the crew every opportunity of recognizing the obstruction itself. But, if the warning is ineffective and a collision seems imminent, the crew should be stopped. In deciding the point at which a crew should be warned, the umpire should bear in mind the experience of the crew involved.*

A crew warned or stopped because of obstruction may continue to race after it has corrected its course, unless the race itself has been stopped.

If two boats are converging in 'neutral water', i.e. very close to the line that the umpire judges to separate their proper courses, and the umpire considers that there is danger of a foul or interference, he may raise the white flag and name both or use the phrase "Both crews move apart".

F18 Instructions to crews given from the bank should be phrased: '..... Club, move to starboard', or '.... Club move to port' as appropriate. If this fails, the umpire may try 'bow-side' or 'stroke-side', or any other words to achieve the desired effect.

F19 The umpire should warn any person he detects offending against the intention of this Rule, and if the offence continues, he should consider giving the crew concerned an Official Warning or disqualifying it. There is no objection to mere encouragement, but every attempt should be made to stop any apparently pre-arranged method of conveying instructions, especially in steering.

F21 The distance between boats at which interference can occur must vary according to conditions, and is entirely a matter for the discretion of the umpire.

F22 In the event of a restart under (b) or (d) being ordered in the early stages of the race, it should take place from the start; otherwise it should take place from the point of stoppage. Care should be taken, in the latter case, to ensure that the boats are in the same relative positions to each other as at the moment of stoppage. If the restart cannot take place immediately because of damage incurred to equipment, the Organising Committee shall decide the time and course for a re-scutt.

F23 'Outside agency' means an object or incident originating outside the boat, and does not cover breakages or accidents in the boat not resulting from external interference, or incidents for which a competitor is to blame.

All regattas and clubs should have available an adequate complement of spare components, and a boatman or skilled hand to carry out running repairs. It is the responsibility of the Organising Committee, and also each crew, to check the boats prior to using them.

F24 The race finish line should be clearly identified by a finish post at water level on the far bank and a post or sight-line on the judges' side of the river.

It is usual to employ two or more judges for a race, and they consult together before giving their decision. If there is a difference of view between the judges on the finish order or the distance to be declared, the view of the chief judge shall prevail.

It is normal practice for the judge to indicate when the first crew crosses the line. This will be necessary if the launch umpire is timing the race. It is also desirable but not mandatory for the benefit of the competing crews. The indication may be the lowering of a white flag, or the ringing of a bell, or both.

The distance by which a boat is declared to have won may be the smallest that can be judged, and a dead heat should be given only when it is impossible to see which boat passed the finish line first.

The judges must take no account of anything that may have happened before the boats pass the finish line, such matters being the responsibility of the starter and umpire.

F26 A separate enclosure, preferably covered, should be provided for the judges in order that they may confer in private before declaring their verdict.

F28 It is the responsibility of the Organising Committee to decide the time and course for any re-scutt; the umpire's responsibility ceases when he orders the re-scutt. Both dead-heated crews may be passed through to the next round of competition, thus avoiding a re-scutt, if the draw and course can accommodate the situation.

SECTION G - DISPUTES AND DISCIPLINARY PROCEDURES

General

G1 The decision of an umpire shall be final and without appeal. The jurisdiction of an umpire, or group of bank-umpires, shall extend over the whole race including the start and the finish.

G2 Race Committees and umpires may decide at their discretion any cases not covered in these Rules.

A report on such cases shall be sent to the Hon. Secretary of the SRA.

Protests

G3 A crew may make an immediate protest at the end of a race against an umpire's decision. A protest should be signalled to the race umpire, if launch based, by the raising of hands as soon as the crew has passed the finish line, or, failing the umpire, to the chief judge.

A protest at a bank-umpired race may be made through the chief judge to the co-ordinating umpire.

A protest may be made by an official club representative on behalf of the crew.

G4 Should an immediate protest to the umpire fail, a further protest may be made to the Race Committee, but appellants should realize that the Race Committee cannot overturn the decision of the race umpire, its powers being limited as described in the Note to Rule C8.

G5 Any protest not satisfactorily settled between the crew concerned and the competition organisers, or any protest involving a poor umpiring or Organising Committee decision, shall be referred in writing by the Captain of the club of the protesting crew to the Chairman of the Qualified Umpires Sub-Committee.

Misrepresentation

G6 No one may compete in an event if not qualified to do so under the Rules of Sections D and E. Anyone found competing in an event while:

- a) not qualified for the event, or
- b) banned from competition, or
- b) competing under a false identity

shall be disqualified from the competition together with the crew, or crews, of which he or she may be a part.

The incident shall be reported to the Hon. Secretary of the SRA, and the SRA Committee may take further action under Rule G10. (See also Rules B5 and B12.)

Unsportsmanlike Behaviour

G7 Competitors, crews, groups of club members, or supporters of a club shall be considered to have engaged in Unsportsmanlike Behaviour if they:

- (a) Wilfully or repeatedly disobey safety instructions (Rule J13)
- (b) Refuse to follow the instructions of an umpire or properly appointed official
- (c) Physically or verbally threaten or abuse another competitor, competition official, helper (including stake boat persons), or members of the public
- (d) Use foul or obscene language in the public hearing, or use foul or obscene gestures in the public view
- (e) Being competitors, misrepresent themselves as in Rule G6
- (f) Display any other form of misconduct deemed by an official to be 'unsportsmanlike'

They shall be subject to disciplinary measures as indicated in Rules G8, G9 and G10.

RULES OF RACING

Disciplinary Measures

- G8 The disciplinary measures in the jurisdiction of any officiating umpire or the Race Committee are:
- (a) A caution,
 - (b) An Official Warning,
 - (c) Disqualification from the race in which the Rules have been infringed.
- G9 The disciplinary measures in the jurisdiction of the Race Committee are:
- (a) A 'public warning',
 - (b) Disqualification of an individual competitor, a crew, or a club from all races at the competition. (Any prizes already won and presented shall be returned and may be re-awarded to the crew finishing second; no entry fees shall be refunded.)
 - (c) If the misconduct is serious enough for the disciplinary measures of (b) above to be imposed, but that action would be ineffective because the competition is effectively over for the competitor, crew, or club involved, the Race Committee may impose similar measures to be effective at the next following competition.
- G10 The disciplinary measure in the jurisdiction of the SRA Committee is a ban from competing without limit, applicable to individuals or clubs. The Committee shall meet not later than three weeks after the competition to hear the case, and may consider both written and verbal evidence, the parties concerned representing themselves. The result of the hearing shall be published to all affiliated clubs and to any affiliated regatta that may be affected by any imposed ban.

EXPLANATORY NOTES AND COMMENTS

- G8(b) Official Warnings given under Rules F9, F13 and J13 shall apply to the race in which they were incurred. Those given under Rules F19, G7 (a) and G7 (b) shall apply to all races in the event in which the crews are involved. Those given under Rules G7(c), (d) or (f) shall apply to all races at the competition in which a crew, an individual competitor or a crew of which he or she is a part, are involved.*
- G9(a) A 'public warning' involves an announcement over the public address system at the competition of the name of the individual competitor, crew or club involved, and that a repetition of the offence may be treated under Rule G9(b).*
- G9(b),(c) In the case of action under these Rules, the chairman of the Race Committee shall send a written report of the incident to the Hon. Secretary of the SRA within three days of the competition.*
- G9(c) Race Committees should be cautious in exercising their powers under this Rule against clubs, owing to the potential loss of income to the competition concerned.*
- G10 This level of action is to be used only for very serious situations, where the individual competitor, crew, or club has attempted to cheat and/or misrepresent, or has exhibited gross misconduct under Rule G7, or has repeated an offence dealt with under Rules G9(b) or G9 (c).*

RULES OF RACING

SECTION H - PROCESSIONAL RACES

H1 Organization

- (a) The responsibility for a processional race competition shall rest with a specific club or with the Skiff Racing Association.
- (b) The responsible organisation shall maintain the Local Event Rules specific to the competition. The SRA Rules of Racing and the guidelines for processional events, in so far as they may be applicable, shall govern the event, but the Local Event Rules shall prevail where there may be conflict.
- (d) The race shall take place annually upon such date and time and at such location as the organisation responsible for the competition shall decide.
- (c) The responsible organisation for the competition shall appoint each year an Organising Committee with local river knowledge to organise the competition. The Organising Committee shall appoint a Race Committee of three or more qualified umpires and shall nominate a chairman from among them who shall be responsible to the Organising Committee for the applications of the Rules of Racing on the day of the race.

The Race Committee shall determine any matters arising in connection with the racing that may not be covered by these Rules.

The chief judge at the finish shall be a member of the Race Committee to provide a focal point if other members of the committee are on station about the course.

H2 Entrance Fee and Entries

- (a) The entrance fee shall be determined each year by the Organising Committee and shall be remitted with each entry.
- (b) The latest time for the receipt of entries shall be decided each year by the Organising Committee.
- (c) Entries shall be accepted from crews comprising members of clubs affiliated to the SRA or to BR, and from such other crews as may be approved by the organising committee. A crew need not all be members of the same club.
- (d) The competition shall be divided up into sections selected from the categories of events in the SRA Rules of Racing, Section E. (Veteran scullers shall not be subject to handicapping.) A competitor may scull in one section only, but, subject to the Organising Committee accepting multi-entries, the same competitor may also cox in one or more other sections, and, subject to the same proviso, a coxswain may cox in any number of sections.

H3 Boats

The skiffs used for the race shall each have bow, centre and stern burden boards and shall conform to the currently-approved dimensional and constructional requirements of the SRA, but locking stretchers with straps, and strung tholes shall not be obligatory

The double skiffs used for the race shall each have a rudder.

The foregoing requirements shall not preclude the use of skiffs whose leading dimensions may exceed those currently approved by the SRA but which otherwise conform to those requirements

Each doubles crew shall include a coxswain who shall weigh, including dead-weight if necessary, not less than 50 kg, and who shall steer from the coxswain's thwart. Dead-weight, if carried, shall be placed beneath the coxswain's thwart.

H4 Programme

- (a) If the entry exceeds the number of boats available the crews shall be raced in divisions, split in order of status whenever possible.
- (b) The order in which the competing crews start shall be decided by ballot, except that the scullers of the winning crew

RULES OF RACING

of the previous year, should they enter as a crew, shall have the option of starting first.

- (c) The Organising Committee shall provide for competitors a programme, listing the officials, the specific course rules and order of sculling in each division.
- (d) The Organising Committee shall provide a pre-course briefing to crews describing potential hazards on the course and any penalties as stated in the rules for the event.

H5. Conduct of Racing

- (a) A crew may start only in its allotted division. A time penalty may be imposed on any crew starting out of its balloted position, the amount of the penalty to be decided by the Race Committee.
- (b) Within each division the crews shall be started at intervals of approximately 20 seconds.
- (c) The time taken by each crew to complete the course shall be measured in such manner as the organising committee shall decide, and the crew or crews that complete the course in the shortest time overall, or the shortest time within a section, shall, subject to disqualification or time penalty, be declared to be the winning crew or crews of the event or the section respectively, but no section shall be recognized in which fewer than two crews enter.
- (d) The progress of the competing crews shall be watched by officials, stationed along the course, who may be umpires (qualified or probationary) or others (race monitors). Each official shall have the powers to warn, to impose a time penalty, and to disqualify (if an umpire) or recommend a disqualification (if a monitor), according to the SRA Rules of Racing and Local Event Rules.
- (e) An umpire intending to disqualify a crew shall if possible notify that crew immediately. Upon being notified of its disqualification, the crew shall ensure that it causes no interference in the remainder of the race. The Umpire shall notify the Race Committee at the finish of the race and the disqualified crew as soon as practicable afterwards.
- (f) Crews infringing any other race rules shall be liable to incur a time penalty up to 30 seconds. If an official considers that a time penalty should be imposed, the amount of the penalty shall be decided by the Race Committee in consultation with the official.
- (g) Crews are subject to the fortunes of the day and can not be compensated for any delays caused by other river users or other competitors.

H6 End of Race

- (a) Any objections or disputes raised by the crew must be lodged with the Race Committee within 20 minutes of the race finishing.
- (b) The Race Committee shall consider any reports of officials regarding possible disqualification or time penalties, and shall confirm the amount of the penalty.
- (c) In case of dispute, the Race Committee shall conduct an inquiry with affected parties
- (d) The Race Committee shall notify any penalized crews of decisions reached and any penalties imposed, before the results are announced

H7. Award of the Trophy

- (a) Prizes may be presented to the winner(s) of the event, and to the winners of sections in which a minimum of three crews, or at the discretion of the organizers two crews, have entered, but the event winner may not also receive a prize as a section winner.
- (b) ~~In accordance with Section D10 of the SRA Rules of Racing, winning the event or a section shall not affect a sculler's status unless it is an Entrant event.~~

GENERAL RULES FOR PROCESSIONAL RACES

- 1 If there are islands in the course, the course rules must specify the correct side on which to pass these islands
- 2 If there are bridges in the course with multiple arches, the course rule must specify through which arches the crews may pass
- 3 Buoys may be placed on the course to direct crews, either for safety reasons or to prevent crews from taking a shorter course. The course rules must state on which side to pass the buoys and declare the purpose of the buoys.
- 4 Crews shall follow normal navigation rules and proceed to the right of centre in the direction of travel
- 5 Crews must be attentive to other river traffic at all times, and take particular care when emerging from behind an island or crossing a channel
- 6 Overtaking is permitted except where specific instructions to the contrary are given. The course regulations must state which crew should move in an overtaking situation. The general convention for skiff racing is that crews being overtaken shall yield the stream by moving away from the bank when going upstream and away from the centre when going downstream, and if a foul occurs, the crew being overtaken shall be at fault if it has failed to move correctly. However the organisers are not obliged to follow this convention if circumstances require otherwise, but then it must be clearly stated which crew is at fault if a foul occurs.
- 7 There may be a need for clarity when crews meet when approaching and turning a bend in the course.
 - 1 If the turn is to the right when proceeding upstream, or to the left when proceeding downstream then the standard overtaking convention above will ensure the overtaking crew is given right of way
 - 2 If the turn is to the left when proceeding upstream or to the right when proceeding downstream, then right of passage changes if the convention above is followed, and so specific instructions must be given.
- 8 A no overtaking zone may be specified, for example through bridges, beside an island, or in a turn to avoid the situation at 7.2. The start and end of no-overtaking zones must be clearly indicated. Crews must not cause interference to following crews by stopping or deliberately slowing down in a no-overtaking zone. An umpire may warn a crew that appears to be doing so.
- 9 Crews that infringe the rules, whether intentionally or not may be subject to penalties.

Disqualification may be awarded for

 - a Disregarding the safety of other river users or competitors. This includes passing the wrong side of buoys that are placed for safety reasons.
 - b Bringing another crew to a halt or fouling other crews repeatedly
 - c Impeding another crew in a no overtaking zone, having received a warning
 - d Using foul language towards another river user not in the race.

A time penalty of up to 30 seconds may be imposed for crews that start out of position or gain unfair advantage

 - a Taking a shorter course by missing buoys or other directional controls
 - b Overtaking in a no overtaking zone.

LIST OF PROCESSIONAL EVENTS

EVENT	ORG	TYPE	DATE	COURSE	Established	TROPHIES
Doubles Marathon	SRA	Doubles	October	Walton	1909/1956 1978	Heldmann Trophy Liz Walsh Trophy
Wraysbury Long Distance Sculls	WSPC	Doubles	May	Runnymede	1984	
Dittons Double Sculls	DSPC	Doubles	May	Thames Ditton	1953 1983	Tiny Knight* Nancy Knight*
SSPC 6K	SSPC	Doubles	June	Sunbury	2012	
Gordon Dear Mixed Marathon	SC	Mixed Doubles	April/May	Teddington	1994	
Simon Mepham Mixed Marathon	TVSC	Mixed Doubles	April/May	Walton	2008	
Singles Marathon	SRA	Singles	October	Walton	1976 1983	Jack Rosewell Trophy Gerald V Birch Trophy
DSPC Singles	DSPC	Singles	May	Thames Ditton	2007	

* The Tiny and Nancy Knight Trophies are awarded to Doubles crews in which neither competitor has won a senior event.

SECTION J - SAFETY REGULATIONS

Organising Committees

- J1 No regatta or processional race shall take place without prior consultation between the organizers and the appropriate navigation authority to ensure that the event can take place under conditions that are safe for competitors and the general public alike.
- J2 The racing course, and the navigation channel for other passing river users, must be marked with clearly visible buoys as required by the navigation authority. Notices must be prominently displayed to warn other river users of the event and the actions required of them.
- J3 In processional races, the areas before the start line and beyond the finish line shall be clear of all locks and weirs and give ample room for crews to be marshalled and turn in the former, and to clear the finish line in the latter, without interfering with other crews or with the course of other river users. Hazardous areas such as shallows, under-water obstructions, narrow passages, side channels and areas where other river traffic crosses the course, shall be conspicuously marked, and identified in the competitors' instructions.
- J4 The Organising Committee shall be responsible for ensuring that medical and life-saving services, as far as practicable in line with the BR Water Safety Code, are provided throughout the competition, both before, during, and after racing periods. It shall ensure that, if considered at risk, any officials and helpers in work boats or launches, and stake-boat persons, particularly if young children are provided with life jackets or buoyancy aids.
- J5 The Organising Committee shall ensure that all competitors and officials are made aware of the circulation pattern to be followed at all times during the period of racing, any regulations regarding marshalling, and practice, warm-up and wind-down areas, and any points of danger on or near the course. They shall also be made aware of the medical support arrangements, the positions of any safety boats and first-aid stations, and the locations of any emergency telephones.
- J6 Notwithstanding any of the regulations in this section, an Organising Committee, its officials and helpers shall not be held responsible for any loss, damage or injury suffered by competitors or spectators.

Race Committees

- J7 The Race Committee shall monitor water and wind conditions throughout the period of the competition. If at any time the Race Committee jointly considers that the conditions jeopardise the requirements of safety or of fair racing, they shall stop or suspend racing until such time as safe and fair conditions are restored. If circumstances permit, the Race Committee should consult with the Organising Committee, or its representative, before taking action and before resuming racing after an enforced break.

Umpires

- J8 It is the primary duty of every umpire, and every other official, to care for the safety of competitors, officials, other water users and the public at large. In particular, umpires should give precedence to the avoidance of collisions in accordance with Rules F17 and F18 and the Notes thereon.
- J9 Processional-race umpires shall give instructions to crews to avert collisions or accidents, and may stop crews for safety reasons. They shall note any breaches of the safety regulations and report such violations to the Race Committee for appropriate penalties.
- J10 The race umpire should halt racing if safety or fairness is compromised, and should involve the Race Committee as soon as possible (see Rule J7).
- J11 A launch used for umpiring should comply with the characteristics in the Note to Rule F6 and, as far as practicable, be equipped with the recommended safety equipment in line with the BR Water Safety Code. Umpires and launch drivers must provide their own life jackets or buoyancy aids if they wish to use them.

RULES OF RACING

Crews

- J12 Crews proceeding to the start, whether in the navigation channel or not, must keep clear of the course and be aware of and leave clear room for the possibility of racing crews straying from the course.
- Other river users going about their business and pleasure should be given precedence.
- J13 Any crew that violates the declared circulation pattern, or that violates Rule J12 or any other mandatory safety regulation, or that is observed executing a dangerous manoeuvre, may be awarded an Official Warning. This penalty may be awarded by any officiating umpire and should be notified immediately to the start for application in the next race for the crew involved.
- J14 All competitors enter a regatta entirely at their own risk (see also Rule J6), but to minimise the risk they should be in good health and able to swim a minimum distance of 50 metres in light clothing and shoes. Coxswains who may be considered at risk, particularly if young, must wear a life jacket or buoyancy aid.

EXPLANATORY NOTES AND COMMENTS

- J6 *It is advisable that an Organising Committee should state in its programmes and official notices a disclaimer in the following words, or similar:*
- 'While the Committee will take all reasonable precautions to ensure the safety of competitors and spectators, and their property, it does not accept responsibility for any loss, damage or injury to persons or property, however caused.'*
- J14 *All clubs are advised to carry and maintain adequate comprehensive insurance to cover personal injury to members on and off the water and personal injury and damage to property or third parties.*

VETERAN RACING

RULES

1. A Veteran sculler is one who has attained the age of 40 years before the 1st January of the current year.
2. Veteran scullers and crews shall receive a handicap each year based on the sculler's age, or the crew's combined ages, at the 1st January of that year. The handicap to be applied is shown in the following table.

<u>SINGLES</u>		<u>DOUBLES</u>	
<u>AGE</u>	<u>HANDICAP</u>	<u>COMBINED AGES</u>	<u>HANDICAP</u>
40-45	Scratch	80-85	Scratch
46-50	2 seconds	86-90	1 seconds
51-55	4 seconds	91-95	2 seconds
56-60	6 seconds	96-100	3 seconds
61-65	8 seconds	101-105	4 seconds
66-70	10 seconds	106-110	5 seconds
71-75	12 seconds	111-115	6 seconds
76-80	14 seconds	116-120	7 seconds
81-85	16 seconds	121-125	8 seconds
		126-130	9 seconds
		131-135	10 seconds
		136-140	11 seconds
		141-145	12 seconds
		146-150	13 seconds

3. A Veteran crew's handicap shall be reduced for every win in non-processional Veteran events and may become negative if the reduction exceeds the age handicap.
 - (a) A single sculler's handicap shall be reduced by 2 seconds for every win in single skiffs, but shall be unaffected by wins in double skiffs.
 - (b) A double crew's handicap shall be reduced by one second for every win by either of its members in double skiffs, but shall be unaffected by wins in single skiffs. The term 'double skiffs' shall include gentlemen's, ladies' and mixed doubles.
4. Scullers and crews with a reduced handicap shall, at the commencement of the next following season, revert to a handicap based only on age.
5. A Veteran Records Recorder shall be appointed each year by the SRA Committee and shall be responsible for keeping a register of Veteran scullers' year of birth and regatta wins.

A Veteran sculler must register with the Recorder his or her year of birth, either directly or by including it on a regatta entry form. Regatta secretaries must apply to the Recorder for Veteran scullers' handicaps, and shall print them in regatta programmes. An unregistered entry, or a regatta entry made without including the birth year, shall be listed as 'Scratch' less any handicap reduction applicable.
6. A Veteran sculler after having won a Senior status event, whether qualifying or not, and whether in single, double, or mixed-double skiffs, shall not enter a Veteran event in that category for the rest of that season.
7. Veteran events shall be raced over the full course. If the course is 500 metres or less, the handicap difference shall be reduced by one second for every full five seconds difference between the handicaps of the two crews. If the course is 700 metres or above, then the handicap difference shall be increased by one second for every full five seconds difference between the handicaps of the two crews.
8. Novice Veteran events shall be subject to the normal Veteran Rules for handicapping, but the reduction in handicap following a win shall not apply if the sculler enters a normal Veteran event. A sculler who wins a normal Veteran event in a particular category of boat, shall not, for the rest of that season, compete in non-processional Novice Veteran events

VETERAN RACING

in the same category of boat.

9. In processional events only, a 'Restricted' classification of Veteran scullers may be used in addition to, or in place of, the 'Open' classification given in Rule 1. To qualify for a Restricted Veteran event in single skiffs, a sculler must have attained the age of 50 years before 1st January of the current year. To qualify for a Restricted Veteran event in double skiffs, both scullers must be Veterans and their combined age must be at least 100 years before 1st January of the current year. Further similar Restricted classifications may be used with the age of a single sculler advancing by increments of 10 years and the combined age of a doubles crew by 20 years. Rule 6 shall apply to all classes of Restricted Veteran events.

THE VETERAN PENNANT

RULES

1. Clubs affiliated to the SRA shall be eligible for award of the Pennant.
2. All competitors eligible to compete for the Pennant must be members of an affiliated club, and must qualify as a veteran on the day of the race.
3. Events that qualify for the Pennant shall be raced in single or double skiffs and include short course regatta events and processional events.
4. The birth year of each competitor on an entry form shall be specified.
5. All races shall comply with the SRA Rules of Racing.
6. All members of a crew, including the coxswain, shall either be a member of the same club, or they may be from different clubs (composite crews) provided the coxswain is a member of one of the sculler's clubs.
7. One point shall be awarded to the club of a winning crew, or half a point to each club of a composite winning crew for an event in which two or more crews have competed.
8. In the exceptional case of an undecided dead heat, the winning crews shall each accrue one point.
9. A Veteran Pennant Points Recorder shall be appointed each year by the SRA Committee and shall be responsible for keeping a register of the points awarded to each club. In the event of a dispute in respect of the points awarded, the Chairman of the SRA Committee and the Hon. Secretary of the SRA shall resolve the dispute, their joint decision being final.
10. The Pennant shall be awarded each year to the club gaining most points. In the case of a tie, through two or more clubs gaining the same number of points, then the clubs concerned shall be declared joint winners, and a Pennant shall be awarded to each club.
12. The Pennant(s) shall be presented to the winning club(s) at some convenient date and location after the last veteran event of the season, the date and location to be decided by the SRA Committee.

THE JUNIOR PENNANT

RULES

1. Clubs affiliated to the SRA shall be eligible for award of the Pennant.
2. All competitors eligible to compete for the Pennant must be members of an affiliated club, and must be aged 12 or over and under 18 on the day of the race.
3. Events that qualify for the Pennant may be in single or double skiffs (no processional, handicap or relay events) and shall be raced in the following age categories. In a doubles event this is defined by the age of the elder sculler of the two:
 - (a) Under 14 on the day of the race (J14).
 - (b) Under 16 on the day of the race (J16).
 - (c) Under 18 on the day of the race (J18).
4. Single events shall be raced in single skiffs as follows
 - (J14). These races may be mixed.
 - (J16). These races must have separate events for male and female competitors.
 - (J18). These races must have separate events for male and female competitors.
5. Doubles events shall be raced in double skiffs
 - (J14). These races may be boy's doubles, girl's doubles or mixed doubles, all racing against each other.
 - (J16). These races must be mixed.
 - (J18). These races must be mixed
6. J14 and J16 crews may race in a higher age category, a win in which shall not prevent the crew members subsequently returning to a lower age category.
7. Coxswains shall not be subject to any minimum weight requirement and may be of either sex and of any age category within the limits of Rule 2, but club captains have the responsibility of ensuring that any coxswain they enter are competent.
8. J18 crews shall race over the full length of the regatta course. J14 & J16 crews shall race over a shortened course (300 to 400 metres), the length to be decided by the Organising Committee of the regatta and specified on the entry form.
9. The birth date of each competitor on an entry form shall be specified.
10. All races shall comply with the SRA Rules of Racing.
11. All members of a crew, including the coxswain, shall either be a member of the same club, or they may be from different clubs (composite crews) provided the coxswain is a member of one of the sculler's clubs.
12. One point shall be awarded to the club of a winning crew, or half a point to each club of a composite winning crew for an event in which two or more crews have competed.
13. Where an event is divided into two or more divisions and two or more prizes are awarded, then one point shall accrue to the winner of each division.
14. In the exceptional case of an undecided dead heat, the winning crews shall each accrue one point.

JUNIOR RACING

15. A Junior Pennant Points Recorder shall be appointed each year by the SRA Committee and shall be responsible for keeping a register of the points awarded to each club. In the event of a dispute in respect of the points awarded, the Chairman of the SRA Committee and the Hon. Secretary of the SRA shall resolve the dispute, their joint decision being final.
16. The Pennant shall be awarded each year to the club gaining most points. In the case of a tie, through two or more clubs gaining the same number of points, then the clubs concerned shall be declared joint winners, and a Pennant shall be awarded to each club.
17. The Pennant(s) shall be presented to the winning club(s) at some convenient date and location after the last Junior event of the season, the date and location to be decided by the SRA Committee.

ORMISTON MEMORIAL TROPHY

RULES

- 1 The trophy shall be in the nature of an inter-club Victor Ludorum award for which points shall be awarded to the winning crew of certain events.
- 2 Clubs affiliated to the SRA shall be eligible for award of the trophy.
- 3 To qualify for points the scullers of the winning crew shall either be members of the same club, or they may be from different clubs (composite crews) provided that the coxswain is a member of one of the sculler's clubs.
4. The following events have one point awarded to the club of the winning crew, or half a point to each club of a winning composite crew.
 - 4.1 Status single- or double-sculling skiff events (i.e. those events in categories D5, D6, D7, D8 and D9 of the SRA Rules of Racing)), whether qualifying or not, which form part of the advertised programme of any SRA-affiliated regatta or any regatta organized by an SRA-affiliated club, and raced under SRA rules.
 - (a) Where an event is divided into two or more divisions and two or more prizes are awarded, then one point shall accrue to the winner of each division.
 - (b) A crew sculling over in a final shall be awarded a point if two or more crews have competed in the event. In the case of a Skiff Championship event being staged with only one entrant, the participating crew shall not qualify for points.
 - 4.2 Each section, categorized by D5, D6, D7, D8 and D9 of the SRA Rules of Racing, in non-bumping processional races held with the approval of the SRA and raced under SRA rules, provided that a minimum of two crews enter that section. If there is only one crew in a section, that crew may still be awarded a point if it is the overall men's, women's or mixed crew winner of the event.
 - 4.3 The Tiny Knight Race and the Nancy Knight Race, if held in substitution for one or more of sections categorised by D6, D7 and D8, provided that a minimum of two crews enter each event.
 - 4.4 In the case of a dead heat (i.e. two or more crews returning the same time) in a section of a non-bumping processional event, or, exceptionally, an unresolved dead heat in a status event, the winning clubs shall each accrue one point, or half a point if the crew is composite. This rule also applies to the Tiny & Nancy Knight races, which have their own methods of resolving dead heats.
5. An additional bonus point, or half a point in the case of winning composite crews, shall be awarded to each winning club of the five Skiff Championship events, other than those excluded from points under rule 4.1(b).
6. An Ormiston Points Recorder shall be appointed each year by the SRA Committee and shall be responsible for keeping a register of the points awarded to each club. In the event of a dispute in respect of the points awarded, the Chairman of the SRA Committee and the Hon. Secretary of the SRA shall resolve the dispute, their joint decision being final.
- 7 The trophy shall be awarded each year to the club gaining most points. In the event of a tie, through two or more clubs gaining the same number of points, then the clubs concerned shall be declared the joint winners of the trophy.
8. The trophy shall be awarded to the winning club(s) immediately after the last SRA event of the season. The SRA shall retain the trophy and engrave it with the name(s) of the winning club(s). The trophy may be borrowed from the association on special occasions subject to a written request to the Hon. Secretary, who shall make the appropriate decision.

MOST IMPROVED SCULLER OF THE YEAR AWARD

RULES

1. The criteria that shall be used in assessing a candidate for the award shall include:
 - (a) The sculler's experience and success prior to the current season.
 - (b) The number of wins and other high placings in races during the current season.
 - (c) The diversity of competition considering long distance and sprint and double and single skiff racing.
 - (d) The determination and general conduct shown during racing.
 - (e) Any special personal circumstances.
2. The Hon. Secretary of the SRA shall, at the end of the season, invite the captain of each affiliated club to nominate any suitable candidates for the award from that club, and supply details on which the nominations are based. It is not obligatory to make a nomination if the captain considers that no sculler satisfies the conditions of the award.
3. The nominations from the affiliated clubs, and any others that may be received, shall be considered by the SRA Qualified Umpires Sub-Committee, who shall select the sculler or scullers, if any, who, in their opinion, most merit the award. They may, if they wish, elicit the opinions of other Qualified Umpires who may have had experience of umpiring races in which the scullers were involved.
4. The winner of the award shall be decided by the SRA Committee on the basis of the recommendations of the Qualified Umpires Sub-Committee, but no award need be made if it is considered that there is no candidate that merits it.
5. The award, an engraved tankard, or such other prize as the SRA Committee may decide on, shall be presented to the winner at the end of the season.
6. There is no bar to a sculler winning the award more than once.

JUNIOR SCULLER OF THE YEAR AWARD

RULES

1. The criteria that shall be used in assessing a candidate for the award shall include:
 - (a) The sculler's commitment to competing in the current season.
 - (b) The number of wins and other high placings in races during the current season.
 - (c) The determination and general conduct shown during racing.
 - (d) Any special personal circumstances.
2. The Hon. Secretary of the SRA shall, at the end of the season, invite the captain of each affiliated club to nominate any suitable candidates for the award from that club, and supply details on which the nominations are based. It is not obligatory to make a nomination if the captain considers that no sculler satisfies the conditions of the award.
3. The SRA Committee shall designate a member or members with oversight of Junior racing, who shall consider nominations from the affiliated clubs, and any others that may be received, and select the sculler or scullers, if any, who, in their opinion, most merit the award. They shall elicit the opinions of the Umpire's Sub-committee and other Umpires who may have had experience of umpiring races in which the scullers were involved.
5. The award shall be presented to the winner on the first suitable occasion.
6. There is no bar to a sculler winning the award more than once.

INTER-CLUB TEAM RACES

DESCRIPTION

The SRA Inter-Club Team Races comprise four competitions for the following trophies:

- The Lowe Cup for gentlemen's single skiffs
- The Davis Challenge Cup for gentlemen's double skiffs
- The Penny Chuter Cup for ladies' single skiffs
- The Churchill Trophy for ladies' double skiffs

RULES

1. Introduction

- 1.1 Each competition is in the nature of a team event, with teams of three single scullers or three doubles crews (each crew must consist of two scullers and a coxswain) representing each club, and is open to clubs affiliated to the SRA or BR.
- 1.2 The competitions shall be organized and controlled by the SRA. A three-person Race Committee shall be appointed each year by the SRA and shall determine any matters arising in connection with the racing that may not be covered by these Rules.
- 1.3 The competitions shall be held under the SRA Rules of Racing in so far as they apply.

2. Entrance Fees and Entries

- 2.1 The entrance fees shall be determined each year by the SRA Committee as necessary to cover expenses.
- 2.2 The latest time for receipt of entries shall be determined by the SRA Committee each year. If only one entry is received for a competition, that competition shall be declared null and void.

3. Strings and Substitutes

- 3.1 Each club shall, in its entry, nominate for the approval of the SRA its first, second and third strings, and its substitutes. The strings shall be nominated in decreasing order of assessed speed over the course being used for the event, with the first string being the fastest. The first, second and third strings shall compete respectively against the first, second and third strings of the other clubs. A club may, if it wishes, enter a reduced team of two strings, in which case they shall be nominated as first and second strings
- 3.2 Prior to the event taking place, the Hon. Secretary of the SRA shall convene a meeting of the SRA Committee and the captains, or their representatives, of the competing clubs. This meeting shall have the power, on a simple majority vote, to alter the order of the strings of any club if its assessment of the relative standards of the strings differs from that as entered. It shall not, however, have the power to alter the composition of any doubles crew as entered.
- 3.3 Each club may nominate as substitutes not more than two scullers and one coxswain for a doubles event, and not more than one sculler for a singles event. A substitute sculler may replace a sculler and a substitute coxswain may replace a coxswain if the replaced sculler or coxswain is incapacitated or absent. A substitute competitor having once raced shall not subsequently be replaced unless he becomes incapacitated or unavoidably absent, in which case he may be replaced by a further nominated substitute if available or by a competitor reinstated under Rule 3.6.
- 3.4 A substitution or reinstatement shall not be made unless the Race Committee agrees, and has been notified not less than 30 minutes before the start time of heat or final.
- 3.5 In the event of one or more substitutions or reinstatements being made, the Race Committee shall review the standard of the changed strings relative to the standard of the strings as entered, and shall determine placement within the team.

INTER CLUB TEAM RACES

- 3.6 In the event of a sculler in a singles race, or any part of a crew in a doubles race, being absent or incapacitated and not replaced, the remaining scullers or crews shall race as entered or as determined by the Race Committee under Rule 3.5. A competitor not participating in one race for either of the above reasons may be reinstated and race later in the event, or act as a substitute. A reinstated sculler in a doubles event may partner any available sculler or substitute.
- 3.7 In exceptional circumstances the Race Committee may, subject to Section C9 of the Rules of Racing, allow a sculler to substitute for a coxswain or vice versa, or otherwise waive any of the above Rules, but only with the agreement of the captains, or their representatives, of all the competing clubs.

4. Boats and Course

Boats shall be provided by the SRA who shall also determine the course over which the race will take place.

5. Order of Sculling and Station Draw

5.1 **In the event that entries are received from two clubs**

The three races between the two clubs shall constitute a final. The stations on which the first-strings shall scull shall be decided by a draw, the stations for the second- and third-strings shall then alternate to give the following pattern:

	<u>Station 1</u>	<u>Station 2</u>
First-String Race	Club A	Club B
Second-String Race	Club B	Club A
Third-String Race	Club A	Club B

5.2 **In the event that entries are received from three clubs, when the competition is being held on a three-station course**

The three races between the three clubs shall constitute a final. The stations on which the first-strings shall scull shall be decided by a draw, the stations for the second- and third-string races shall then follow this pattern:

	<u>Station 1</u>	<u>Station 2</u>	<u>Station 3</u>
First-String Race	Club A	Club B	Club C
Second-String Race	Club B	Club C	Club A
Third-String Race	Club C	Club A	Club B

5.3 **In the event that entries are received from three clubs when the competition is being held on a two-station course**

The competition shall comprise nine races, which shall follow the pattern shown below. The clubs and stations for the first race shall be decided by a draw.

	<u>Station 1</u>	<u>Station 2</u>
First-String Race	Club A	Club B
Second-String Race	Club B	Club C
Third-String Race	Club C	Club A
First-String Race	Club B	Club C
Second-String Race	Club C	Club A
Third-String Race	Club A	Club B
First-String Race	Club C	Club A
Second-String Race	Club A	Club B
Third-String Race	Club B	Club C

5.4 **In the event that entries are received from four clubs on either a two- or three-station course**

Two heats and a final shall be sculled using only two stations, the final being between the winning teams of each heat. The races in the two heats shall follow the alternating pattern given below, the clubs and stations for the first two races being decided by a draw. The race pattern in the final shall be determined by the procedures of Section

INTER CLUB TEAM RACES

5.1.

	<u>Station 1</u>	<u>Station 2</u>
First-String Race	Club A	Club B
First-String Race	Club C	Club D
Second-String Race	Club B	Club A
Second-String Race	Club D	Club C
Third-String Race	Club A	Club B
Third-String Race	Club C	Club D

5.5 In the event that entries are received from five clubs on a two-station course

Two teams selected by a draw, shall race in a preliminary heat in accordance with Section 5.1. The winning team and the remaining three teams shall then race in two further heats and a final in accordance with Section 5.4. It is better if, in the pattern of Section 5.4, the winner of the preliminary heat is either Club C or Club D, rather than Club A or Club B, as this gives the whole team one extra race interval between the preliminary heat and the semi-final.

5.6 In the event that entries are received from five clubs on a three-station course

Two teams, selected by a draw, shall race in a heat in accordance with Section 5.1, and the remaining three teams shall race in another heat in accordance with Section 5.2. The races in the two heats shall follow an alternating pattern similar to that in Section 5.4. The winners of each heat shall then race in a final in accordance with Section 5.1.

5.7 In the event that entries are received from six clubs on a two station course

There are two possibilities:

- (a) Four teams, selected by a draw, shall race in two preliminary heats in accordance with Section 5.4. The two winners shall then race the two remaining teams in two semi-finals, again in accordance with Section 5.4. The two winners of the semi-finals shall then race in a final in accordance with Section 5.1.

This scheme requires a total of 15 races, but the teams in the preliminary heats have a potential maximum of three races whereas the remaining teams have a potential maximum of only two.

- (b) All six teams shall race in three heats following the pattern given below, the clubs and stations for the first three races being decided by a draw. The three winners shall then race in a final in accordance with Section 5.3.

	<u>Station 1</u>	<u>Station 2</u>
First-String Race	Club A	Club B
First-String Race	Club C	Club D
First-String Race	Club E	Club F
Second-String Race	Club B	Club A
Second-String Race	Club D	Club C
Second-String Race	Club F	Club E
Third-String Race	Club A	Club B
Third-String Race	Club C	Club D
Third-String Race	Club E	Club F

This scheme is fairer than scheme (a) in that all the heat-winning teams race three times, but it requires 18 races. It is to be preferred to scheme (a) if time is available.

INTER CLUB TEAM RACES

5.8 In the event that entries are received from six clubs on a three-station course

All six teams shall race in two heats following the pattern given below, the clubs and stations for the first two races being decided by a draw. The winners shall then race in a final in accordance with Section 5.1.

	<u>Station 1</u>	<u>Station 2</u>	<u>Station 3</u>
First-String Race	Club A	Club B	Club C
First-String Race	Club D	Club E	Club F
Second-String Race	Club B	Club C	Club A
Second-String Race	Club E	Club F	Club D
Third-String Race	Club C	Club A	Club B
Third-String Race	Club F	Club D	Club E

5.9 In the event that entries are received from more than six clubs, or that more than three stations are available, the SRA Committee shall decide the race pattern for the competition, using a combination or an extension of the patterns given above.

6. Award of Points and Medals

Points shall be awarded as follows:

6.1 When racing two-abreast:

- (a) 3 points to the winner, 1 point to the loser. A crew disqualified or who fails to complete the course, except by reason of circumstances over which it has, in the opinion of the umpire, no control, shall receive no points.
- (b) Crews dead-heating shall receive 3 points each.

6.2 When racing three-abreast:

- (a) 5 points to the winner, 3 points to the second and 1 point to the third. A crew disqualified or who fails to complete the course, except by reason of circumstances over which it has, in the opinion of the umpire, no control, shall receive no points.
- (b) Crews dead-heating for first place shall receive 5 points each, the third crew 1 point. Crews dead-heating in second place shall receive 3 points each. If all three crews dead-heat they shall receive 5 points each.

6.3 The winning team in a heat or final shall be the one whose members gain the most points or, in the case of a tie, are adjudged the winners after following the procedures of Section 7. Each member of a winning team or a tying team in a final shall be awarded a medal.

7. Procedures in the case of Ties

7.1 In the event of a tie between two or more teams in a heat or final, the following procedures shall be adopted, but, notwithstanding what follows, two teams tying in a heat may, at the discretion of the Race Committee, pass into the final if there is a station available.

7.2 **A Tie between Two Teams Racing Two-Abreast**

Any dead-heats shall be re-sculled. If this does not produce a decision, or if dead-heats are not involved, the winning team shall be adjudged to be the tying team with the higher number of first-string points or, if the first-strings are equal, to be that team with the higher number of second-string points.

7.3 **A Tie between Two Teams out of Three, Racing Three-Abreast**

The points for the two tying teams shall be recalculated as if the third team had not competed, using the point-scoring system of section 6.1 above. If this does not produce a decision, the further procedures of Section 7.1 shall be applied.

INTER CLUB TEAM RACES

7.4 **A Tie between Two Teams out of Three, Racing Two-Abreast (Triangular contest as in Section 5.3)**

The points for the two tying teams shall be recalculated using only the points scored against each other. If this does not produce a decision, the further procedures of Section 7.1 shall be applied.

7.5 **A Tie between Three Teams Racing Two- or Three-Abreast**

Any dead-heats shall be re-sculled, the points awarded being appropriate to the number of crews racing in the original race. If this results in a further tie between three teams, or if dead-heats are not involved, the winning team shall be adjudged to be the team with the highest number of first-string points or, if all first-strings are equal, to be the team with the highest number of second-string points. If re-sculling the dead heats results in a tie between two of the three teams, the further procedures of Sections 7.3 or 7.4 shall be applied as appropriate, except that no further dead-heats shall be re-sculled.

7.6 **Unresolved Ties**

If, after following the above procedures, there should still result a tie between two or more teams in a heat, the procedures must be repeated until a decision is reached, but two tying teams may pass into the final if there is a station available.

If, after following the above procedures, there should still result a tie between two or more teams in a final, the clubs concerned shall hold the challenge trophy equally.

8. Trophies

8.1 The challenge trophies, medals and dies are the property of the SRA.

8.2 The respective challenge trophy shall be awarded to the captain of the winning team or, in the case of a tie, to the captains of the teams tying. The SRA shall retain the trophy and engrave it with the name(s) of the winning club(s) and, in the case of the Lowe Cup, the names of the winning team(s). The trophy may be borrowed from the SRA on special occasions subject to a written request to the Hon. Secretary, who shall make the appropriate decision.

GUIDELINES TO CLUBS FOR THE INTER-CLUB TEAM RACES

1 PURPOSE

These Guidelines explain the responsibilities of Clubs when hosting the Inter-Club races. The rules of the Inter Club Team Races are given in the SRA Handbook. Each club takes it in turn to hold the Inter-Club event and the date is determined by the SRA in the Five Year plan and agreed by all clubs each year. For completeness the responsibilities of the SRA and other clubs are also listed.

2 RESPONSIBILITIES

SRA Responsibilities

- Confirm date and venue with the club concerned
- Check for availability of boats
- Organise additional boat transport if necessary
- Send out and receive entries (usually in August)
- Convene Committee meeting to review entries
- Appoint an Organising Marshall to oversee racing on the day
- Arrange sufficient Umpires for the event
- Arrange Umpires Launches for the event
- Arrange recorders and other officials at the finish
- Schedule Races
- Produce a programme and ensure it is made available to clubs and crews
- Set up recorder's tent and table
- Hold pre-race meeting on the day with club Captains

Host Club Responsibilities

- Notify Environment Agency of Date
- Provide facilities and refreshments
- Lay and unlay the Course
- Provide the Stake Boats
- Staff the Stake Boats
- Ensure Racing boats are launched and are fit for use
- Provide Raft Marshalls
- Provide First Aiders

Entrant Club Responsibilities

- Ensure Crews arrive at venue in time to race
- Provide Blades
- Notify SRA Organising Marshall of any crew changes before the start of the event

3 HOST CLUB PROCESSES

Before The Day

The SRA Committee will communicate with the Host club to confirm the date. The Host club must then notify the Environment Agency of the date and event.

The Host club will inform the SRA whether there are sufficient boats at the club or whether additional boats will be required from other clubs. It is then the SRA's responsibility to ensure that any additional boats are delivered in time for the event.

The Host club must make arrangements with the SRA to ensure that buoys and anchors for the course are delivered in advance, and confirm the exact line of the course. The SRA must state whether there is to be two or three lane racing.

INTER CLUB TEAM RACES

Prior To The Event

The Host club must ensure that their premises are open and manned at least an hour before the start of the event.

The Host club must assist in setting out the Officials tent and launching Umpires launches

The Host Club must review the SRA Programme to ensure that it can support it throughout the day, and notify the SRA Organising Marshall of any difficulties that might be experienced.

The Host club must lay the course, as defined in agreement with the SRA, with buoys and anchors provided by the SRA.

The Host Club must arrange for Stake boats (2 or 3 according to number of lanes required) to be set out on the course and for arrangements to be in place for changing stake boat staff on the water

The Host club must arrange a rota of Stake boat staff such that there are sufficient staff for all boats with a change after every **hour**?

The Host club must ensure that all racing boats – from their own fleet and from those delivered by the SRA – are on the water 30 minutes before the start of racing.

The Host club must ensure that all racing boats are fit for use (pins and strings intact and stretcher attachments sound) and drained of excess water.

The Host Club must arrange a raft marshalling team consisting of

A Caller - who is fully aware of the programme at all times and calls crews in time to race

Two Assistants, always in attendance, who supervise crews entering and leaving boats safely – no assistant to leave the landing stage without ensuring a replacement

The Host Club must ensure that individuals are identified and are present who can administer first aid.

After The Event

The Host club must ensure all racing boats are taken off the water and if necessary reloaded on the trailer

The Host club must unlay the course, remove stake boats and arrange for all buoys and anchors to be made available for the next event.

The Host Club must assist the SRA in preparing facilities for the presentation of awards.